

Frugel-Horn Mk3

06-may-2018 | © 2010-2018 Frugal-Horn.com

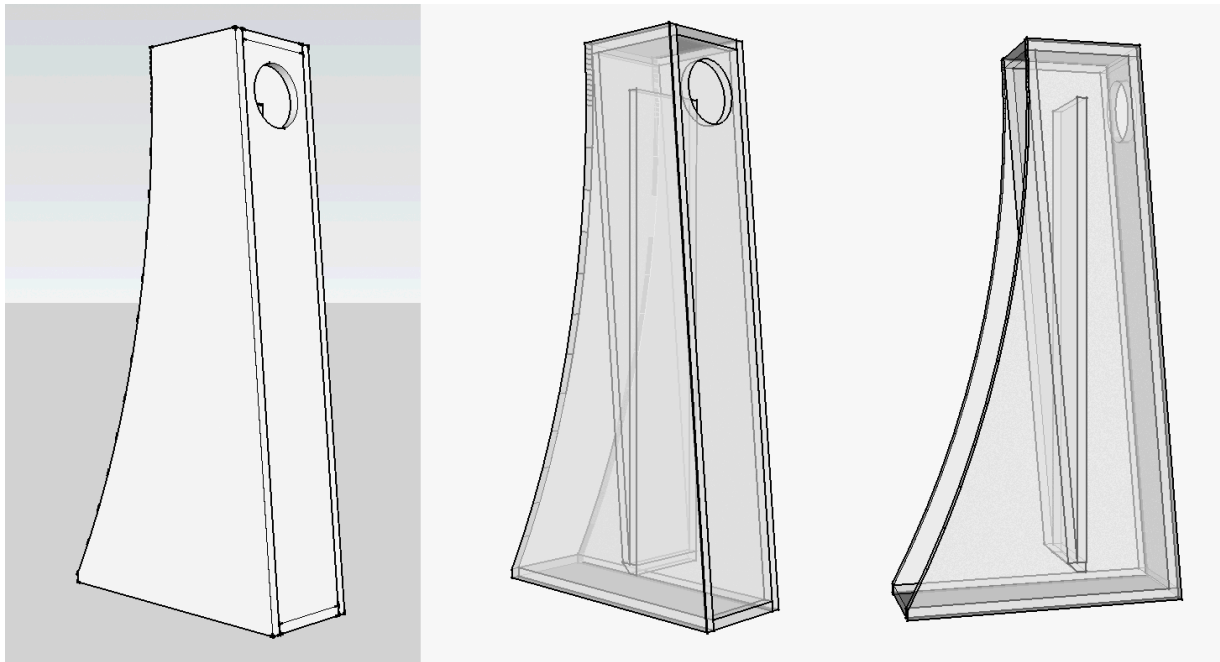

In late 2006 – '07 a small group of enthusiasts collaborated to develop a compact, inexpensive corner-horn design for the DIY community. This project became the very successful Frugel-Horn, which even spawned an extremely expensive commercial adaptation.

The Frugel-Horn Mk3 [FH3] is a well tested design, with the objectives of improving upon the performance of the original box in a substantially simpler cabinet that would be tolerant of a wide range of drive units. Topologically, it is a tapered hypex corner-horn (approximated by 2 conical sections) with an internal choke serving as a low pass filter. The curved terminus is carried over from Ron Clarke's contribution to the original cabinet, and helps the wavefront exiting the horn mouth to return to its more natural spherical shape.

The cabinet has to date been successfully tested with Fostex FE126En, FE126e, FE127e, FF105wk, FF125wk, FE138eSR*, Mark Audio CHR-70, CHP-70, Alpair7, A7.3, A7p, Pluvia Seven, CSS EL70, Tangband W5-1611, more. Any 4-5" (100-130mm) driver is worth trying. Adjustment & tuning of the cabinet is accomplished with varying amounts of damping, and proximity to rear boundary walls / corners.

** (this driver does bass really well in FH3, but has other issues which preclude it being recommended)*

FH3 is made freely available for DIY builders to make their own cabinets; we see it as an introduction to back-loaded horns, from which people may wish in future to move on to larger and / or more complicated designs.

The 1st supraBaffle turned out to be awkward, a simpler supraBaffle. Defectors have been sketched but interest has not pushed its completion, doubling as a stealthWoofer a bit greater.

Note: any commercial entity intent on manufacturing complete speakers or flat-paks for resale will need to follow the guidelines on the Frugal-Horn site: www.frugal-horn.com/use.html

This project's contributors:

DIYers who went ahead, assisted in beta testing, offered comment and suggestions

diyAudio: host for interactive discussion threads

Scott Lindgren <<http://www.wodendesign.com/>> design & documentation

Ron Clarke: the curved mouth

Chris Bobiak: Original test builds & drawing contribution

Colin Topps: drawing contribution

Your name here: you can help with FAQ, assembly diagrams & pictures, photo gallery. Probably more.

Local cottage industry to make & distribute flat-paks encouraged, please contact Dave (david@planet10-hifi.com)

Major Sponsors
& Cheerleaders



Drawings/Contents

i0/ Intro
i1/ Pictures
i2/ Notes

FH3-0/ Plan 12mm
FH3-1/ Plan 15mm
FH3-1.1/ Details 15mm
FH3-2/ Plan 15mm + 18mm baffle
FH3-3/ Plan 16mm
FH3-4/ Plan 18mm

FHx/ Plan 5/8"

FH3-5/ Plan 3/4"
FH3-6/ Side pattern creation
FH3-7/ Alternate Choke Point Execution
FH3-8/ Side template (metric 15mm)
FH3-9/ Side template (imperial 15mm)
FH3-10/ swappable supraBaffle (updated)
FH3-11/ simple supraBaffle

D-0/ Damping

D-1/ full size side felt template (15mm)

C-0/ 5x5 15mm cut plan
C-1/ 4x8 15mm cut plan
C-2/ 4x8 18mm simple cut plan
C-3/ 4x8 18mm cut plan (updated)
C-4/ 4x8 18mm alternate cut plan (updated)

FH3-x/ Stacked FH3 Plan 15mm
FH3-x/ Stacked FH3 MTM options

Centres for HT – FE126En, A7.3, FF125wk, EL70, A7, CHR70.x

Driver drawings – Alpair 7x, EL70, CHx70, Pluvia 7, FE126, FF105wk, FF125wk, FE103 Sol

please email me <david@planet10-hifi.com> with corrections & suggestions to make this document more useful

Pictures

25-february-2012

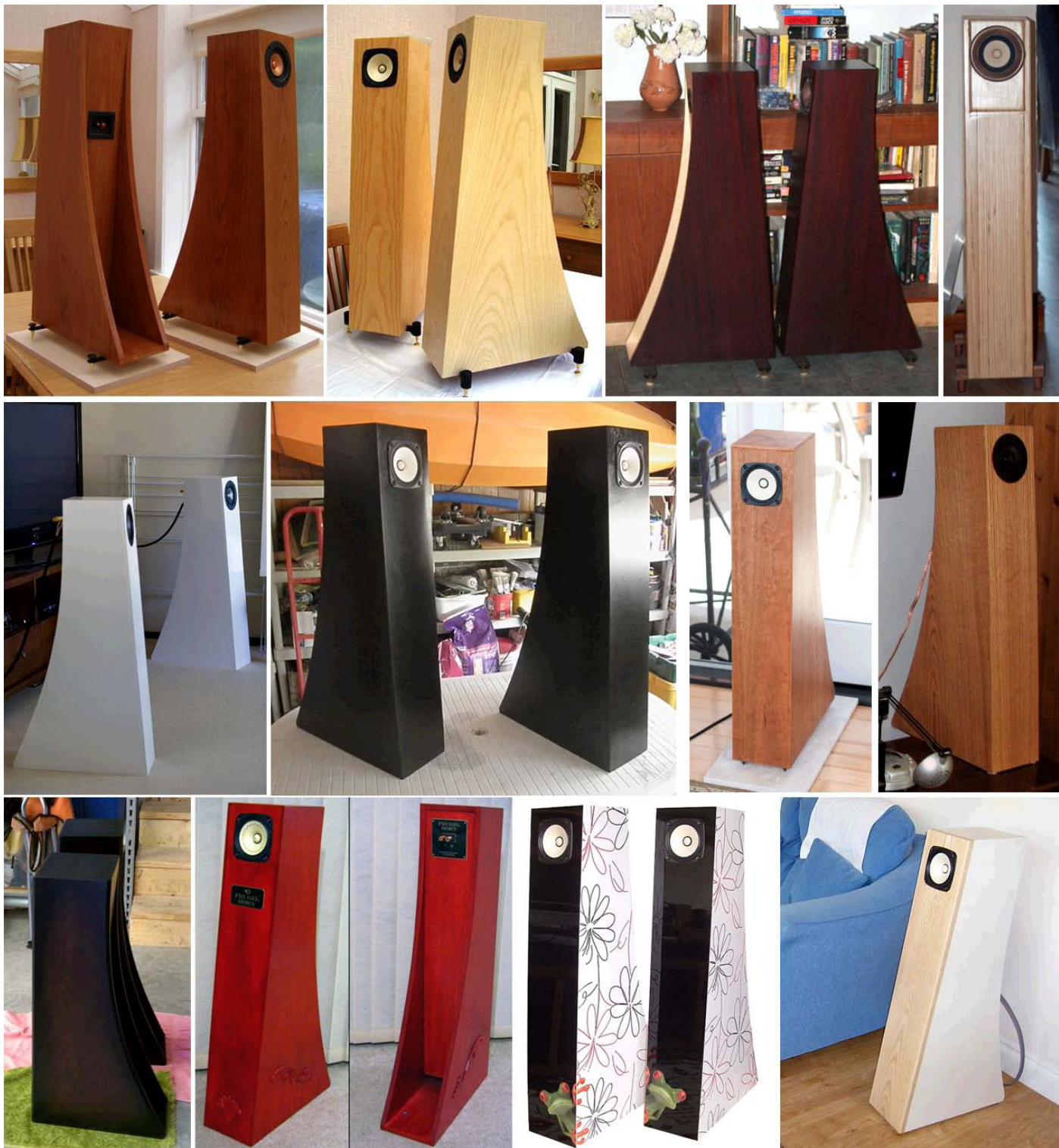

more pictures at <http://www.diyaudio.com/forums/full-range/199849-fh3-build-gallery.html>

Notes

30-september-2011

Notes

o/ quality multi-ply/plywood is recommended. In general, void free, the greater number of plies the better

- 1/ reference build is 15mm plywood, to allow rebate for some drivers 18mm baffles recommended (ie Alpair 7)
- 2/ if MDF or particle board used a minimum panelthickness of 18mm, good multi-ply minimum 12mm
- 3/ the most difficult detail in the build is the joint at the bottom of back, inside divider. A number of means to achieve this are detailed
- 4/ a removable vestigial supraBaffle is shown that allows experimentation with different drivers
- 5/ a full size supraBaffle can be added as shown in the Frugel-Horn Mk1 document
- 6/ A full height rear deflector based on that shown in the Frugel-Horn Mk1 document can be added
- 7/ a stealthWoofers based on a full-height deflector is under development.

Donations

Frugel-Horns have always been free for DIY builders to construct. We received many inquiries by builders who wanted to send some money. For this iteration we would encourage you to pay it forward with a donation of money or time to some charitable organization. Listed below are some chosen by the three main contributors to the design & documentation. Quite literally, every little helps.

Royal British Legion: www.britishlegion.org.uk
Alzheimer's Research UK: www.alzheimersresearchuk.org
Cancer Research UK: www.cancerresearchuk.org
Donor's Choose: www.donorschoose.org
Save The Children: www.savethechildren.org
Big Brothers Big Sisters: www.bbbs.org
[Chris 1](#)
[Chris 2](#)
[Chris 3](#)

for those without major woodworking kit, a growing number of independent flat-pak vendors are coming on-line. Canada (North America), Netherlands & UK (Europe) & Australia as of this document revision

Comments & tips pulled from forum posts

Bob Brines:
Taking Colin's diagram (*sheet C-2*), here is how I would one-man it out of a 4x8 panel.

o. Build yourself a T-square cutting guide out of scrap material. You can find the instructions out there on the Internet.

oo. I have a 3'x6' sacrificial table top on a pair of saw horses. I can still manage to get a 4x8 sheet of plywood on it, but I can no longer get a sheet of MDF on it. For MDF, I just drop the sheet on the driveway and put 4 2x4's under it.

1. With a circular saw, cut off the 4 140mm pieces.

2. Cut between the remaining doubled pieces.

3. Now you can rip the individual pieces on a table saw as long as you can rig some kind of outflow table. I have a jig that fits my router table so that it can double as an outflow table for the table saw. Of course, if you don't have a table saw, you can do this with a circular saw and the rip fence you made above.

You can get the two cross cuts done at Lowes'/HD (speaking to the USA now), but my experience is that their panel saws are not square in any axis and I have to re-cut the ends. Also, the utility blade in their saw really tears up the cut. I have a 60 tooth blade in my circular saw that does an acceptable job. Not as good as the 80 tooth blade in my table saw, but acceptable.

That's my technique. YMMV.

Bob

PDRCanada:
Another tip for cutting sheet goods on saw horses.....

Go to your nearest hardware store buy a 2'x4' pc of 2 or 3" white styrofoam and a roll of duct tape.

Cut the styro to match the top of your saw horses.....use the duct tape to fasten it around the top of the horse.

You can now cut your sheets with out hanging them over the saw horses. Just cut thru the styro.....make sure your styro is deeper than your saw cut.

When the styro gets beat up...remove and replace.

This method is used on jobsites all over to cut large panels.

Poultrygeist:
After much frustration in searching for 1/2" (12mm) cotton or wool felt I found an unlimited supply at my local auto junk yard. The carpet backing from 1990's Fords is 1/2 inch thick, works great and costs nothing. Had it not been up for sale I would have scavenged my own Mustang but instead I found a F150 donor which surrendered enough felt for a herd of horns.

Notes:

- 1/ drawn with 12mm material
- 2/ optional ~300 mm wide/diameter supra-baffle not shown. Its purpose is to move the baffle-step drop off to where the horn action starts flattening lower midrange FR
- 3/ intended for Fostex FE126En, CHR-70, Alpair 7, EL70
- 4/ damping will differ for each driver

Frugal-Horn Mk3 1v01
sheet FH3-o – 12mm Plan

designed by S Lindgren | drawn by dld
06-may-2018
© 2010-2018 Frugal-Horn.com

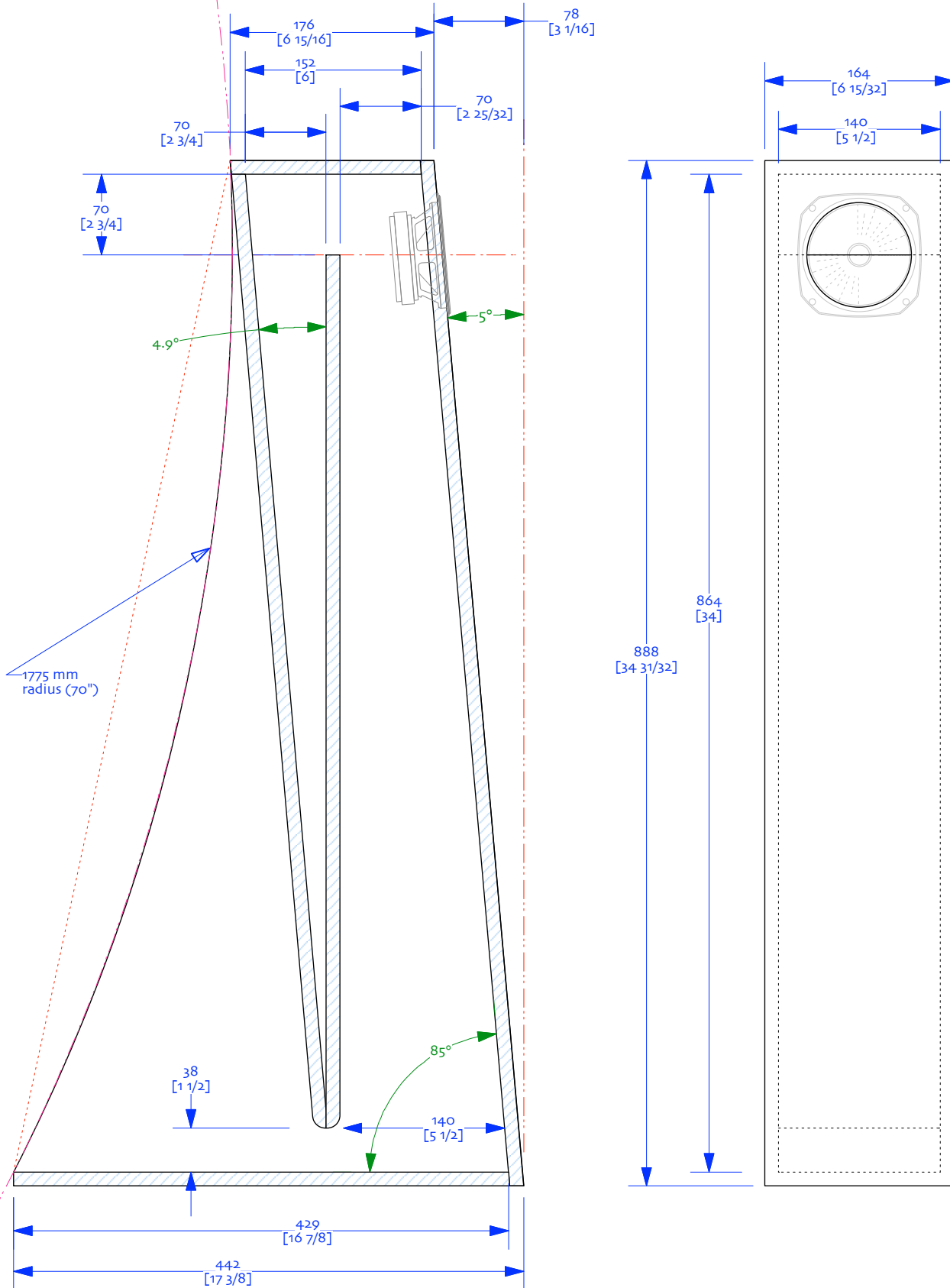

Notes:

- 1/ drawn with 15mm material
- 2/ optional ~300 mm wide/diameter supra-baffle not shown. Its purpose is to move the baffle-step drop off to where the horn action starts flattening lower midrange FR
- 3/ intended for Fostex FE126En, CHR-70, Alpair 7, EL70
- 4/ damping will differ for each driver

Frugal-Horn Mk3 1v01
sheet FH3-1 – 15mm Plan

designed by S Lindgren | drawn by dld
06-may-2018
© 2010-18 Frugal-Horn.com

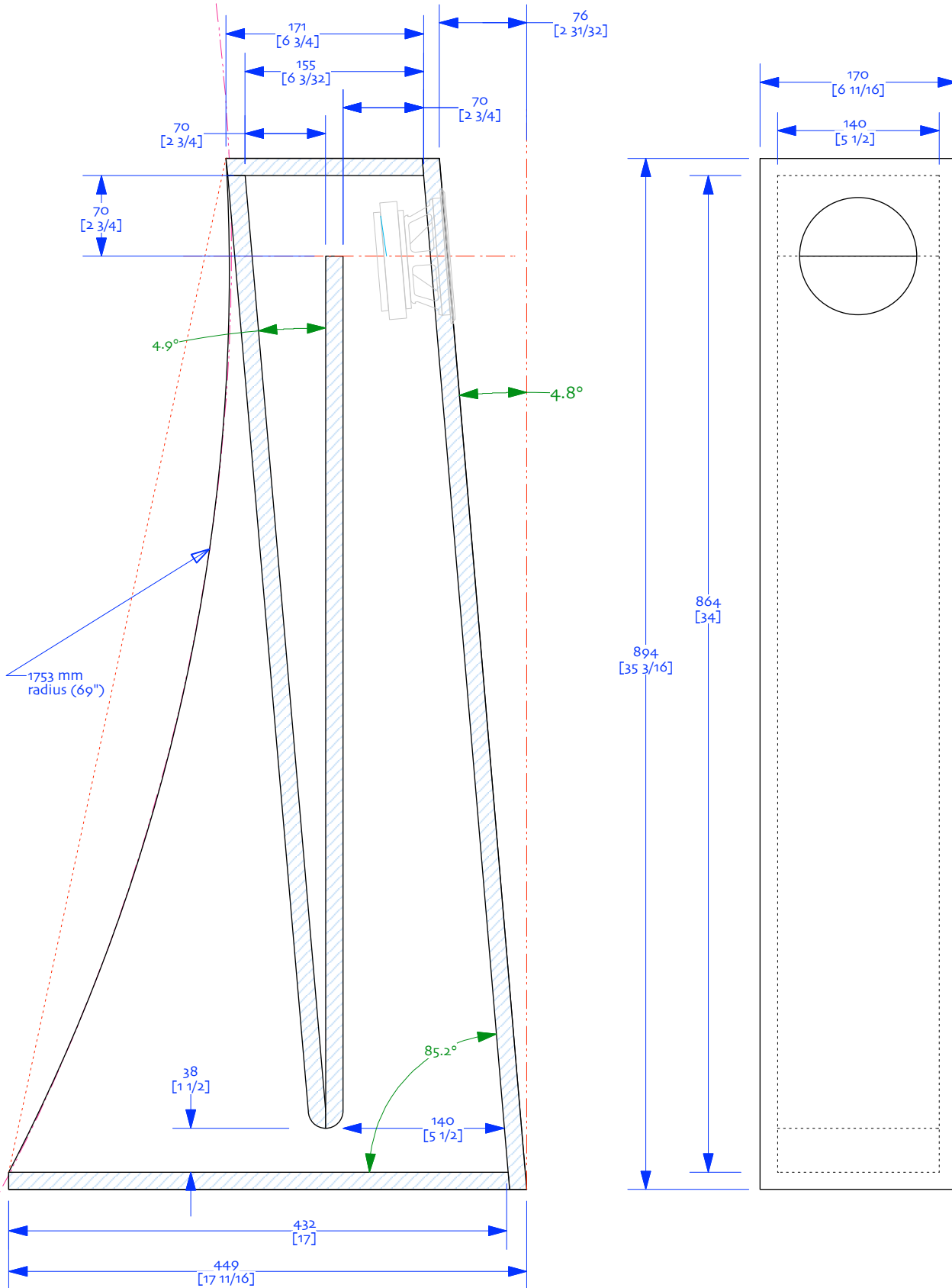

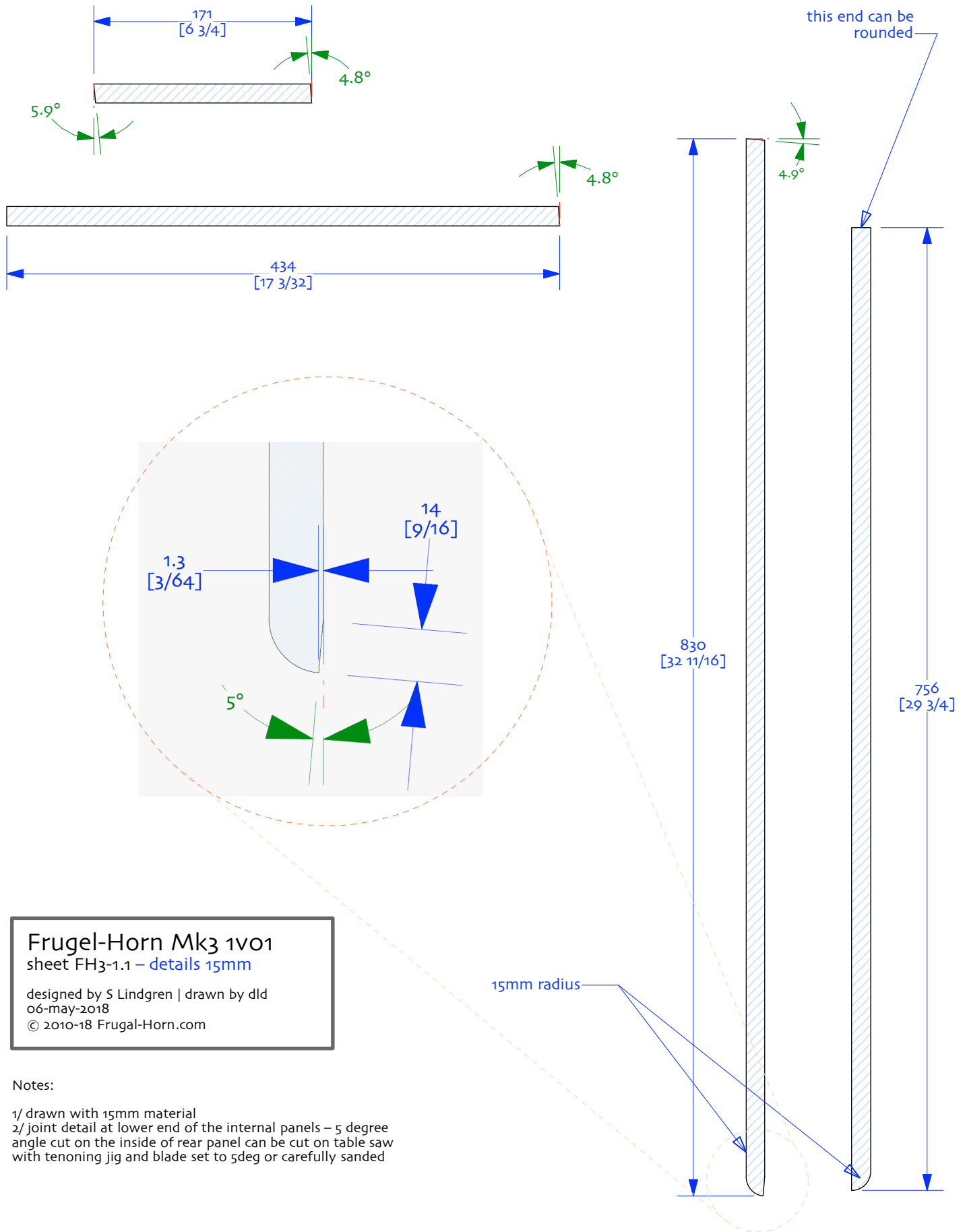

Frugel-Horn Mk3 1v01
 sheet FH3-1.1 – details 15mm
 designed by S Lindgren | drawn by dld
 06-may-2018
 © 2010-18 Frugal-Horn.com

Notes:

- 1/ drawn with 15mm material
- 2/ joint detail at lower end of the internal panels – 5 degree angle cut on the inside of rear panel can be cut on table saw with tenoning jig and blade set to 5deg or carefully sanded

Notes:

- 1/ drawn with 15mm material
- 2/ optional ~300 mm wide/diameter supra-baffle not shown. Its purpose is to move the baffle-step drop off to where the horn action starts flattening lower midrange FR
- 3/ intended for Fostex FE126En, CHR-70, Alpair 7, EL70
- 4/ damping will differ for each driver

Frugal-Horn Mk3 1v01
 sheet FH3-2 – 15mm Plan w 18mm
 baffle

designed by S Lindgren | drawn by dld
 06-may-2018
 © 2010-18 Frugal-Horn.com

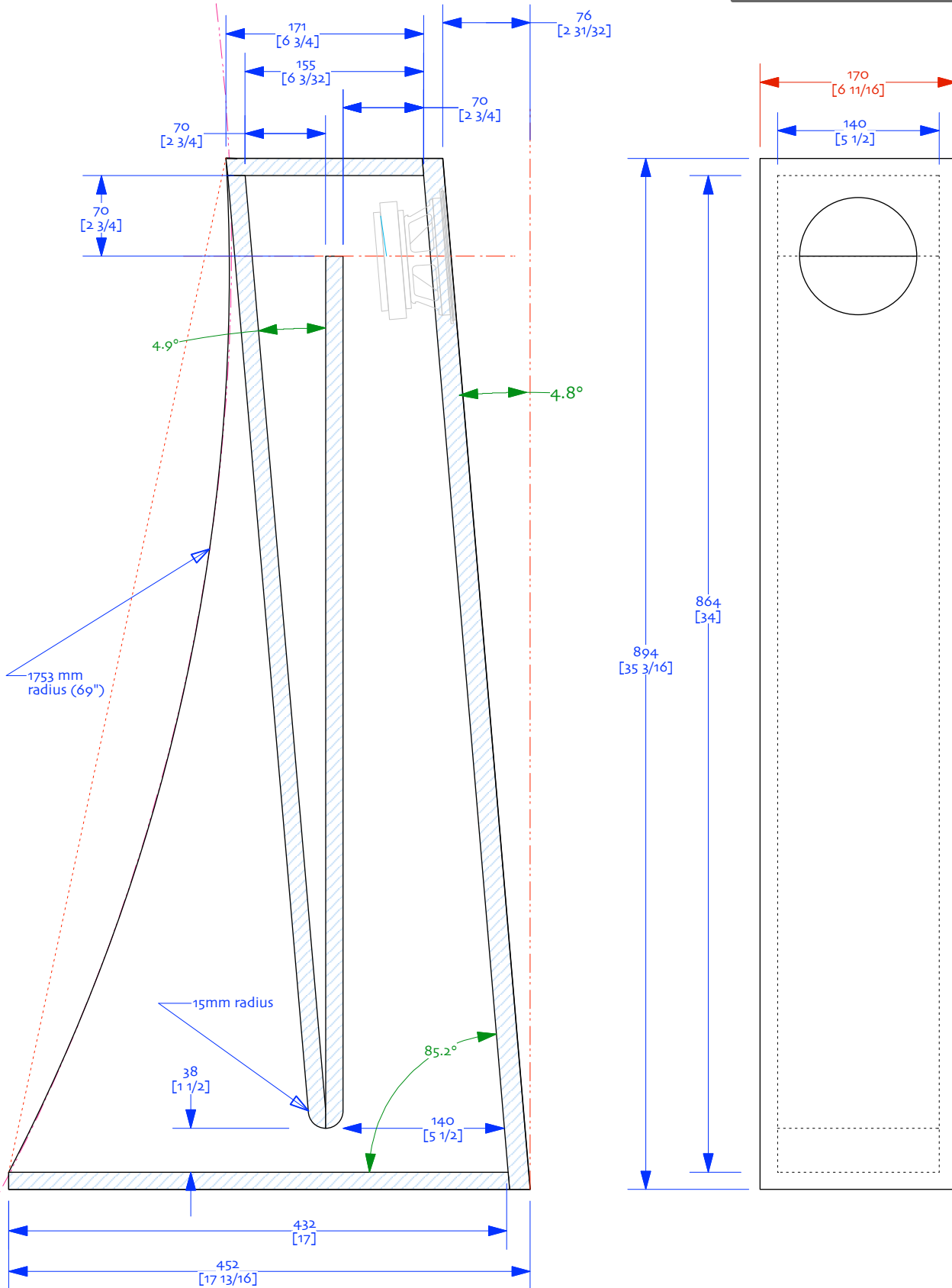

Notes:

- 1/ drawn with 16mm material
- 2/ optional ~300 mm wide/diameter supra-baffle not shown. Its purpose is to move the baffle-step drop off to where the horn action starts flattening lower midrange FR

Frugal-Horn Mk3 1v01
sheet FH3-3 – 16mm Plan

designed by S Lindgren | drawn by dld
06-may-2018
© 2010-18 Frugal-Horn.com

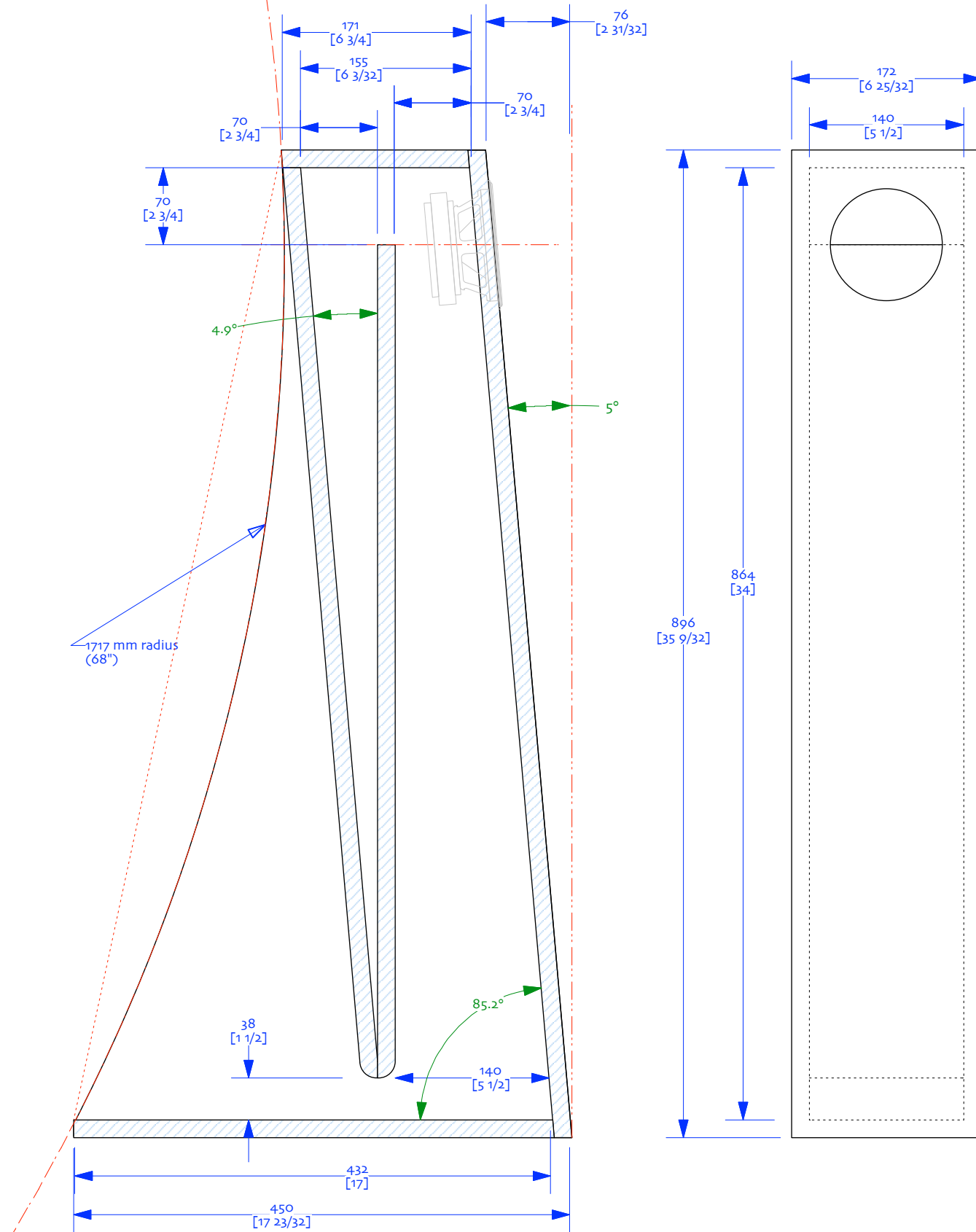

Notes:

- 1/ drawn with 15mm material
- 2/ optional ~300 mm wide/diameter supra-baffle not shown. Its purpose is to move the baffle-step drop off to where the horn action starts flattening lower midrange FR

Frugel-Horn Mk3 1v01
sheet FH3-4 - 18mm Plan

designed by S Lindgren | drawn by dld
06-may-2018
© 2010-18 Frugel-Horn.com

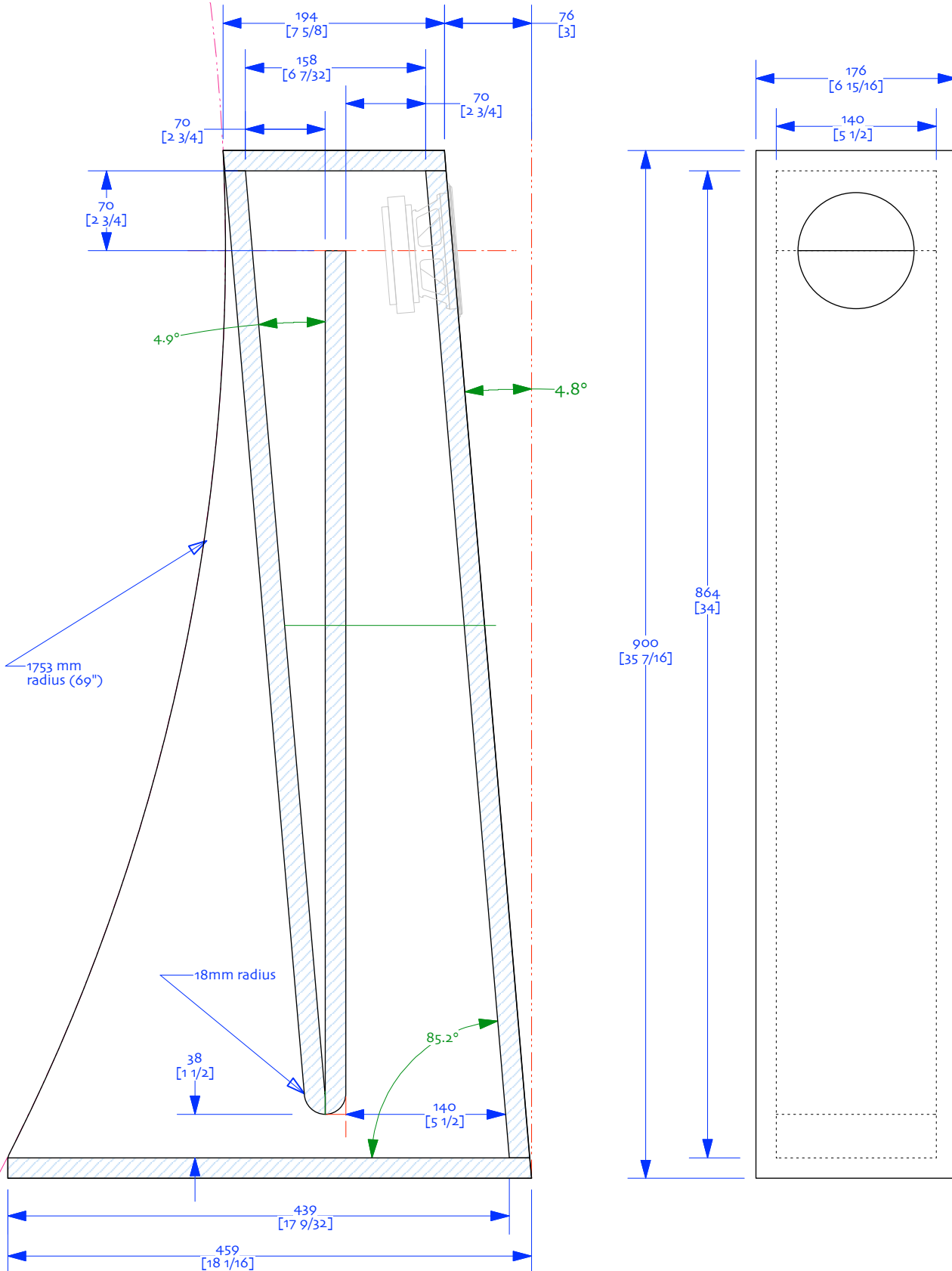

Notes:

- 1/ drawn with 15mm material
- 2/ optional ~300 mm wide/diameter supra-baffle not shown. Its purpose is to move the baffle-step drop off to where the horn action starts flattening lower midrange FR

Frugel-Horn Mk3 1v01
sheet FH3-5 - 3/4" Plan

designed by S Lindgren | drawn by dld
05-may-2018
© 2010-18 Frugel-Horn.com

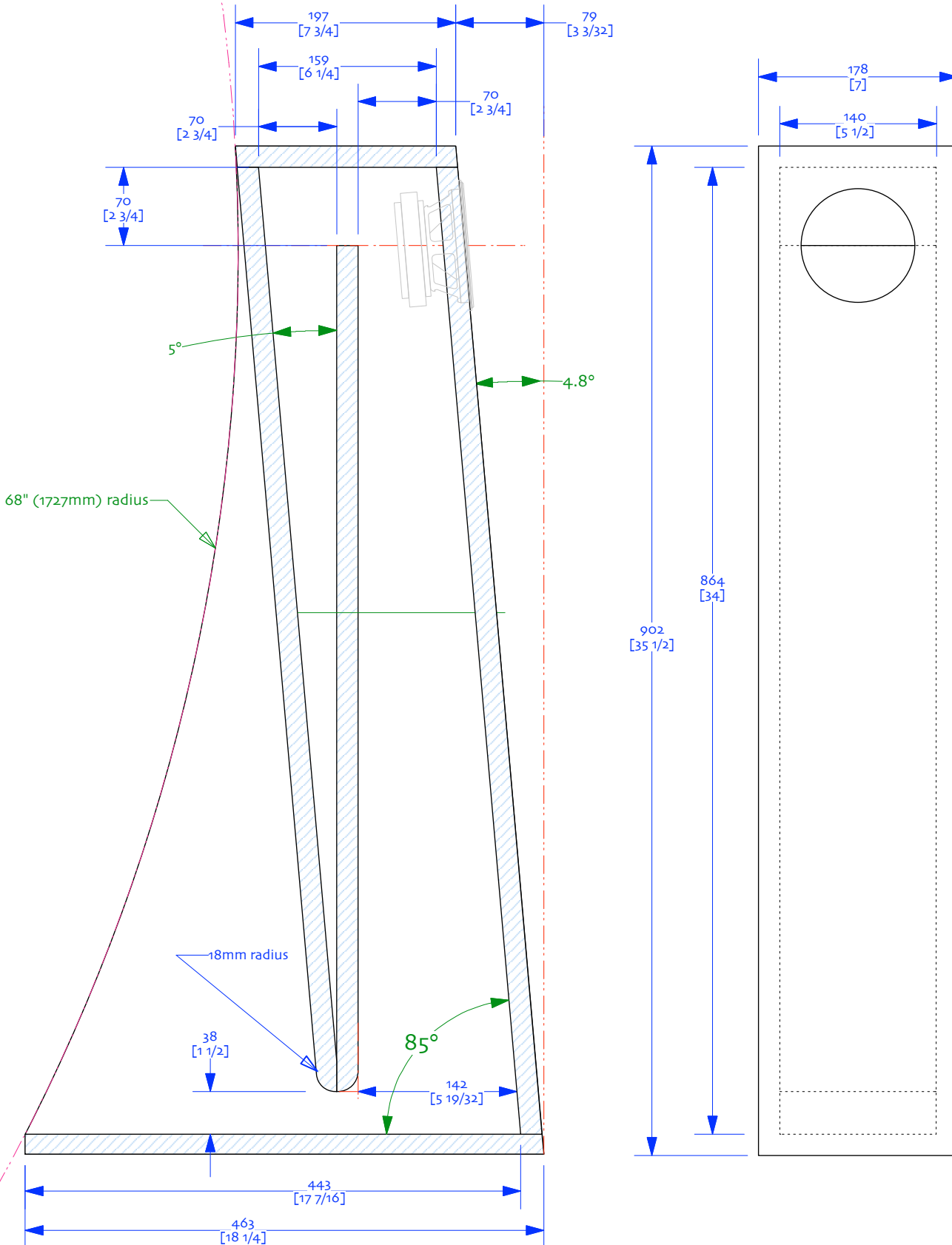

Frugal-Horn Mk3 1vo

sheet FH3-6 – curve chord & height

designed by S Lindgren | drawn by dld
27-september-2011
© 2010, 2011 Frugal-Horn.com

To fabricating a side panel template by hand, the curve can easily be drawn using a narrow flexible board (1/4" MDF works great) and the 4 points as dimensioned.

Mark points A,B (chord ends), C (chord centre line) and D (segment height) on the work-piece. Use a square to draw a perpendicular line (C-D)

Clamp or screw a wood block straddling the centreline at D, clamp the flexible board to this block and each end of the chord (A & B) then draw the curve.

Cut to the outside with jig or band saw, and carefully sand to line

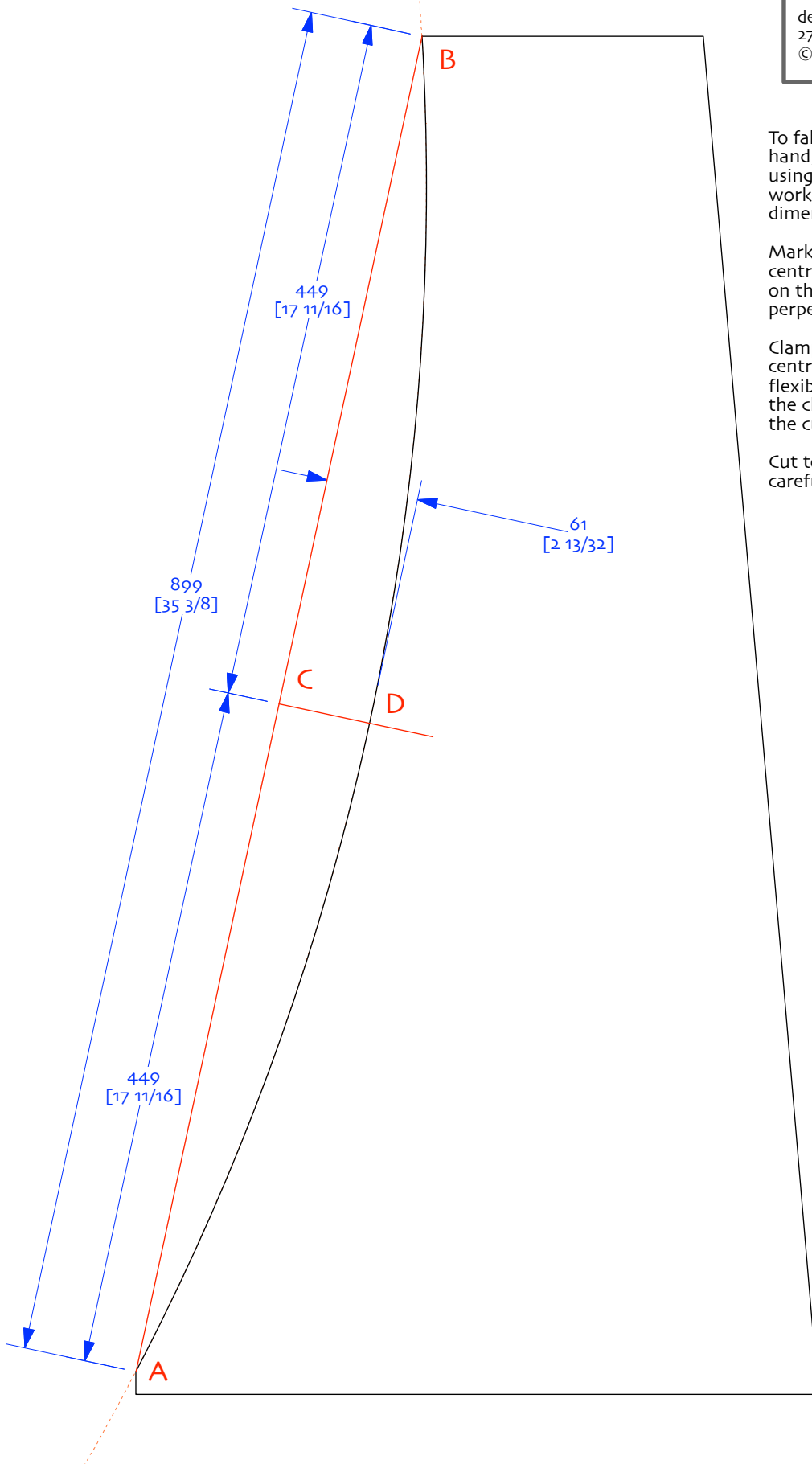

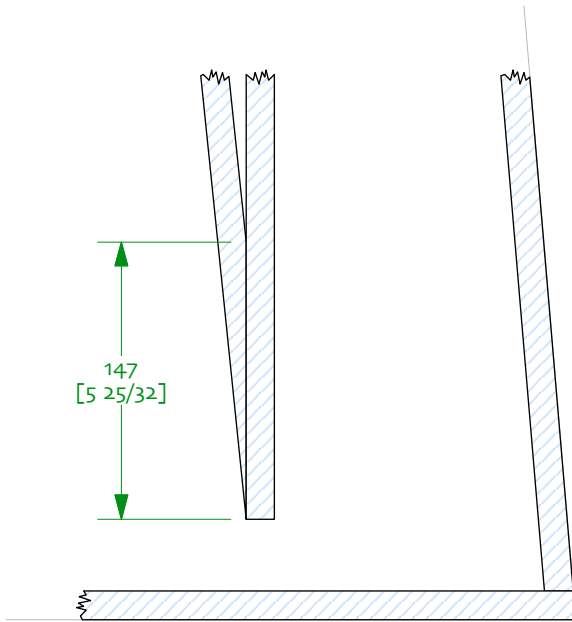

Note: example uses 15mm material

As originally designed
A difficult piece to cut

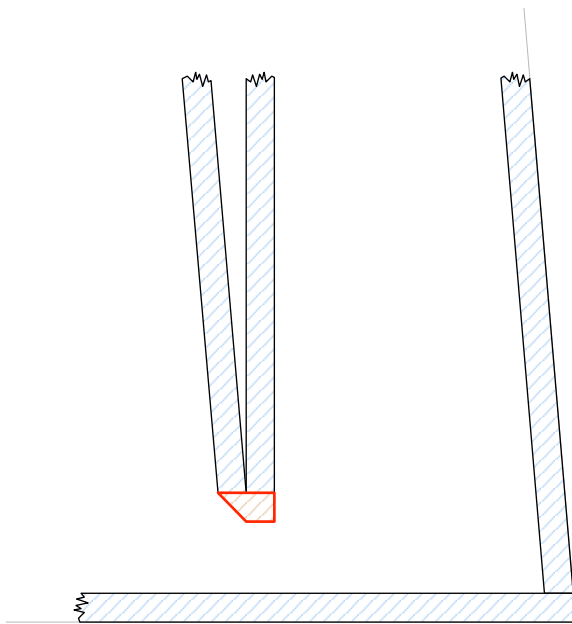

Modified for easier build
Adds an additional piece, not all that tolerant of thicker material

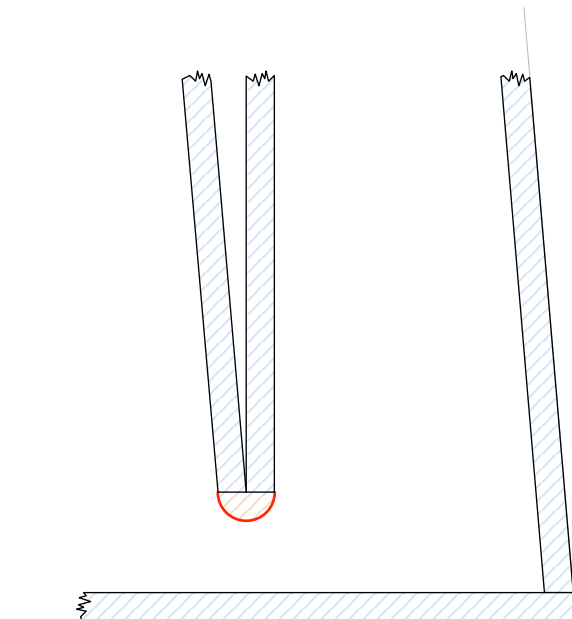

Alternate easier build
Overcomes material thickness issues. Requires extra material – 1/2 round with radius of build material

Frugel-Horn Mk3 1v01
sheet FH3-7 – alternate choke point execution
designed by S Lindgren | drawn by dld
06-may-2018
© 2010-18 Frugal-Horn.com

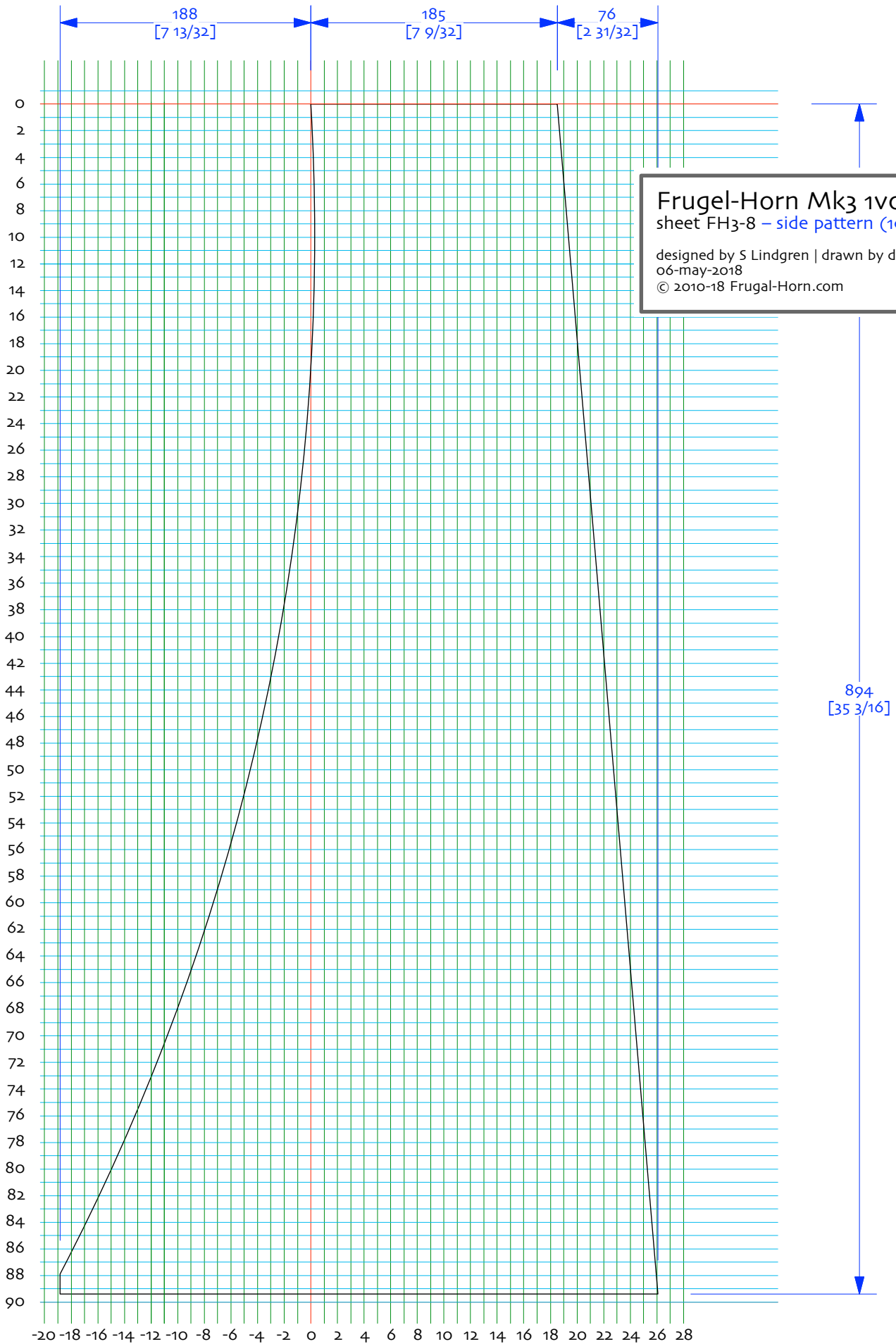

Frugel-Horn Mk3 1v01
 sheet FH3-8 – side pattern (1cm grid)
 designed by S Lindgren | drawn by dld
 06-may-2018
 © 2010-18 Frugal-Horn.com

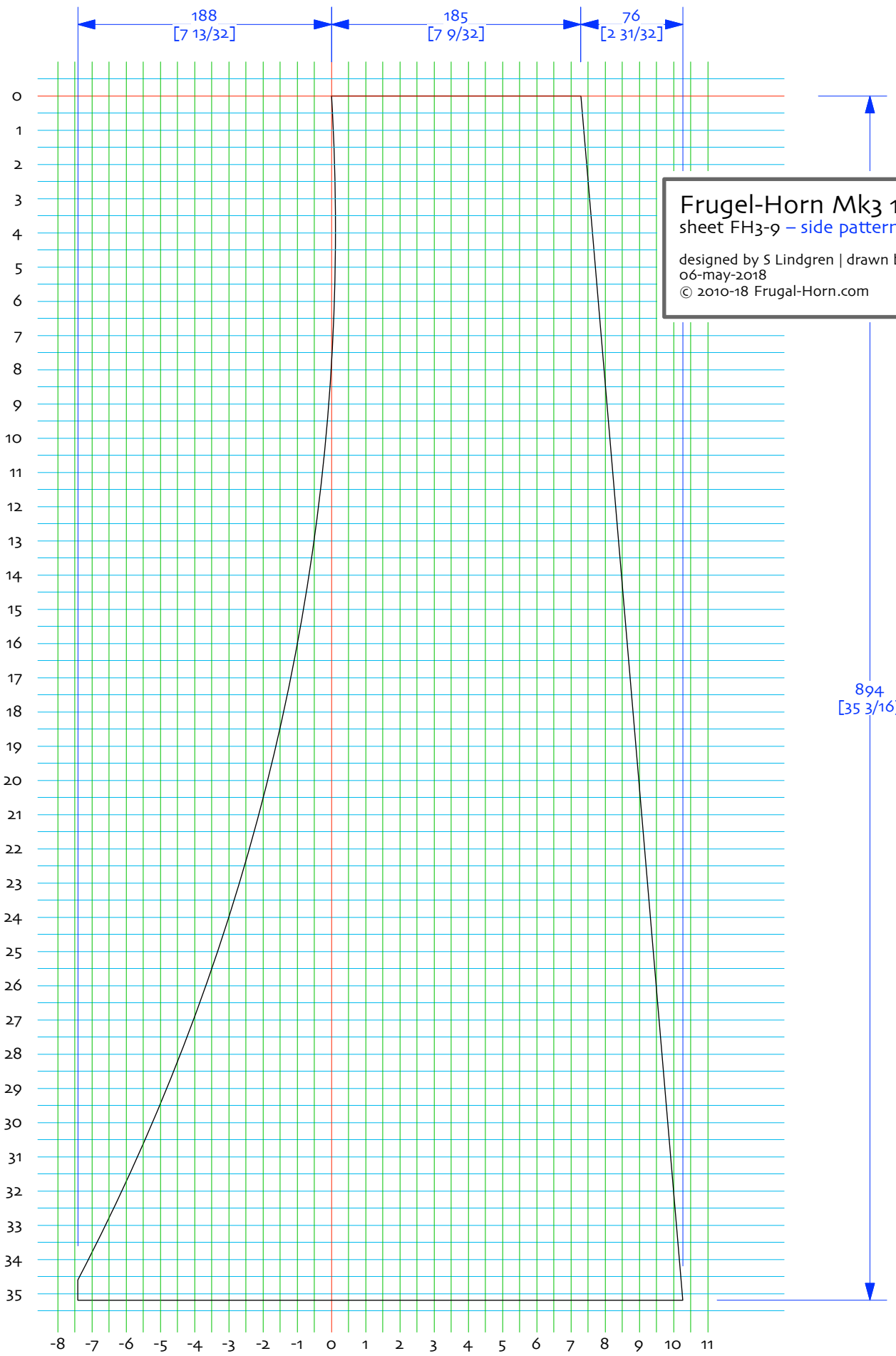

Frugel-Horn Mk3 1v01
 sheet FH3-9 – side pattern (1/2" grid)
 designed by S Lindgren | drawn by dld
 06-may-2018
 © 2010-18 Frugal-Horn.com

Frugel-Horn Mk3 1v01

sheet FH3-10 – removable
 supraBaffle (15mm)
 designed by C Bobiak | drawn by did
 06-may-2018
 © 2010-18Frugal-Horn.com

Notes:

o/ drawn with 18mm panels
 1/ shown on FH3 in 15mm material

BaffleCutout

cut out on backside of sB is
 20mm down from the top
 (15mm panels, would be 23mm
 down with 18mm panels)

these dimensions allow for a small gap
 to accomodate veneer,laminate etc, if
 needed the wings can be made tight to
 the sides and the vertical edges can be
 sanded flush.

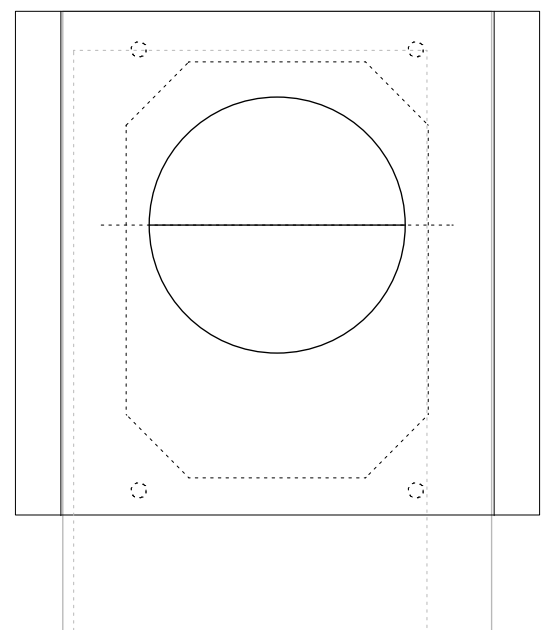
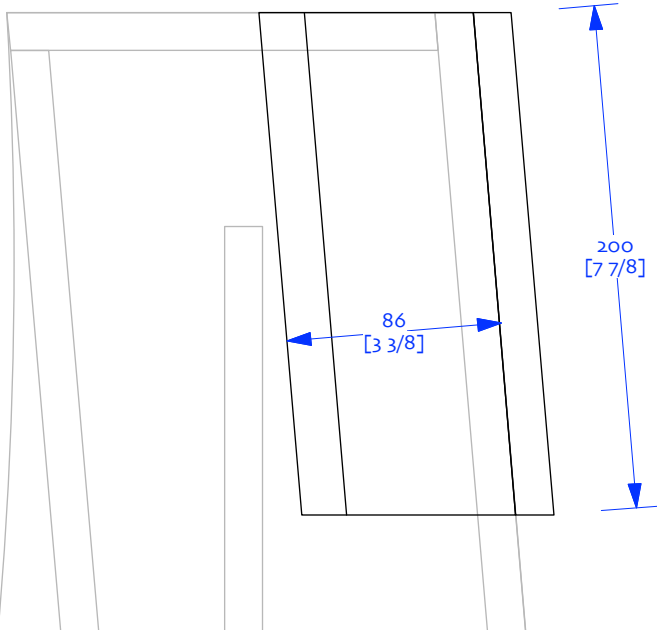
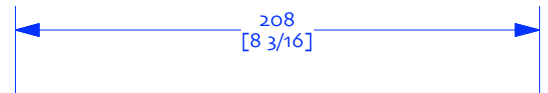
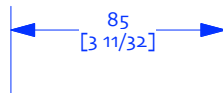
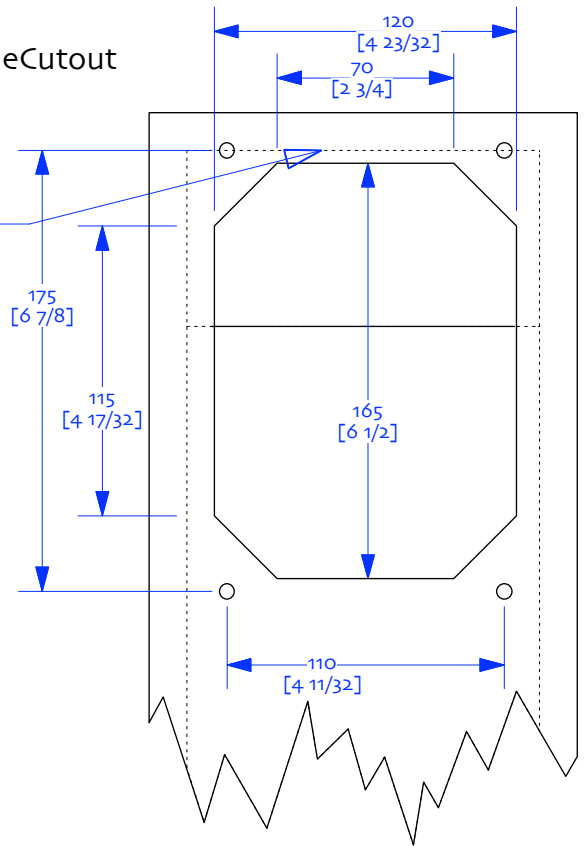
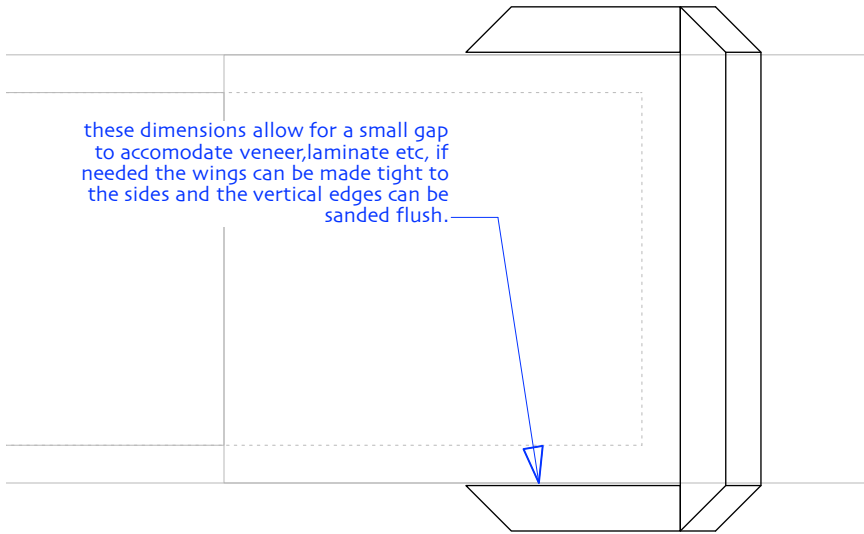

Frugel-Horn Mk3 1v01
 sheet FH3-11 – simple supraBaffle
 (15mm)

designed by C Bobiak | drawn by dld
 06-may-2018
 © 2010-18Frugal-Horn.com

Notes:

o/ drawn with 18mm panels
 1/ shown on FH3 in 15mm material

BaffleCutout

cut out on backside of sB is
 20mm down from the top
 (15mm panels, would be 23mm
 down with 18mm panels)

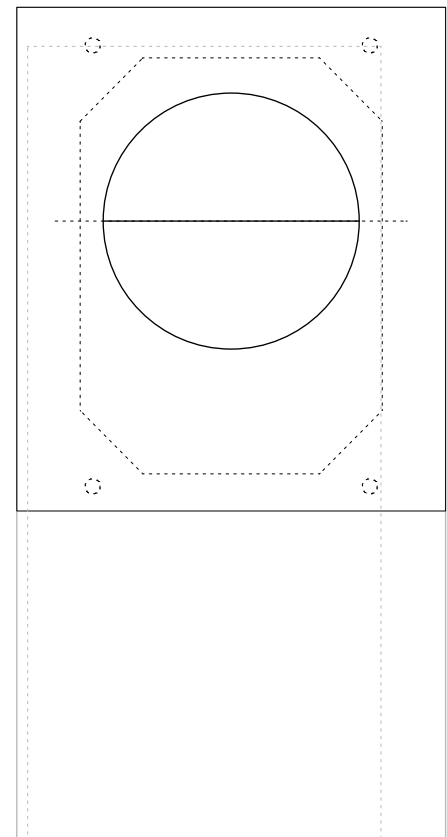
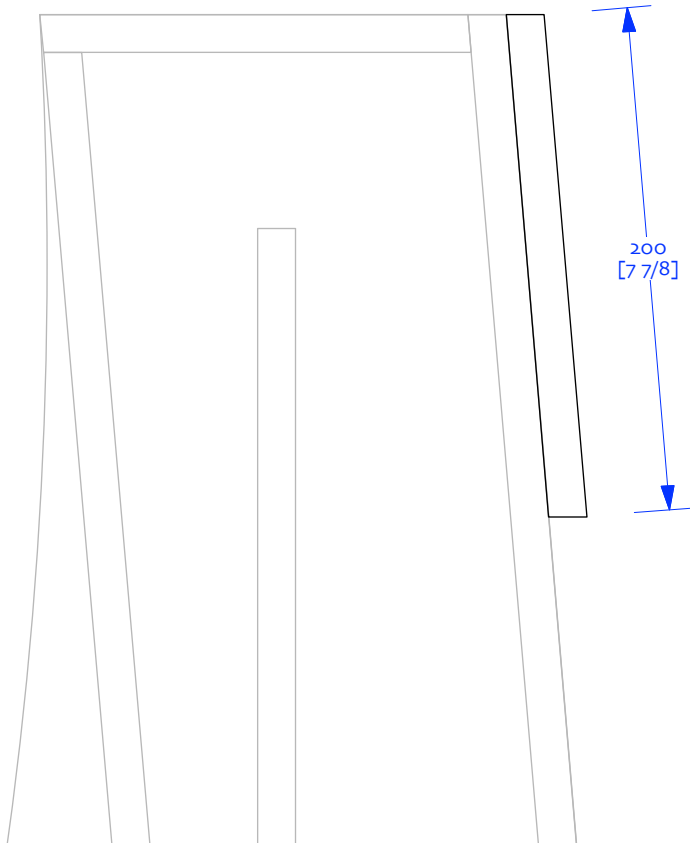
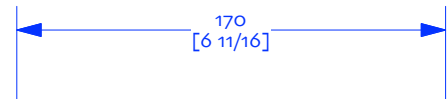
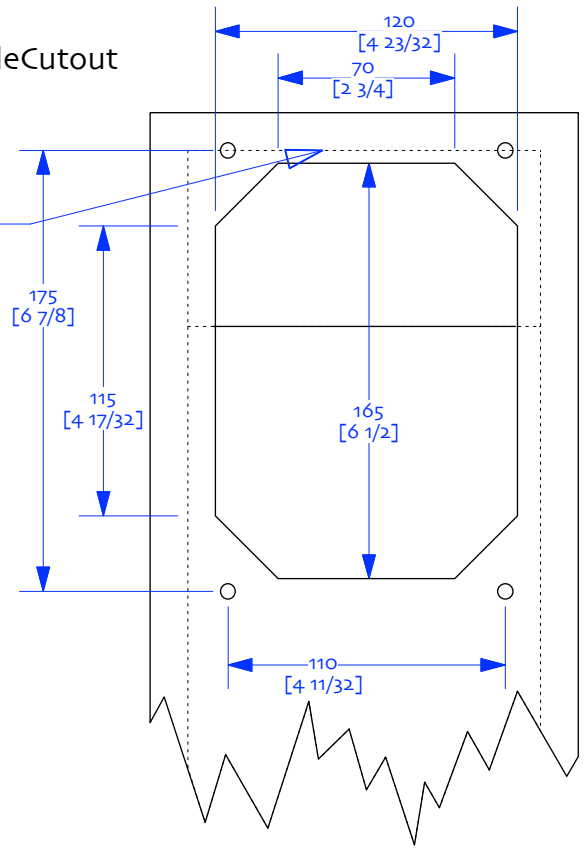

1/2" (12mm) cotton or wool felt



poly-fluff (BAF, acoustistuff, pillow stuffing -- different colours represent different "zones" to add stuffing too)

- 1/ FE126En blue + orange
- 2/ CHz70 blue + orange + 20-40g
- 3/ EL70 blue + orange + 20-40g
- 4/ A7x blue + orange + 20-40g
- 5/ FF105/125wk blue + orange + 20-40g

Frugel-Horn Mk3 1v01 sheet D-o – damping plan

designed by S Lindgren | drawn by dld
06-may-2018
© 2010-18 Frugel-Horn.com

increasing density as you approach the point. Take the equal density fluff on the right and squeeze it into the point (~30g = 1 oz)

walls lined around driver to minimize reflections

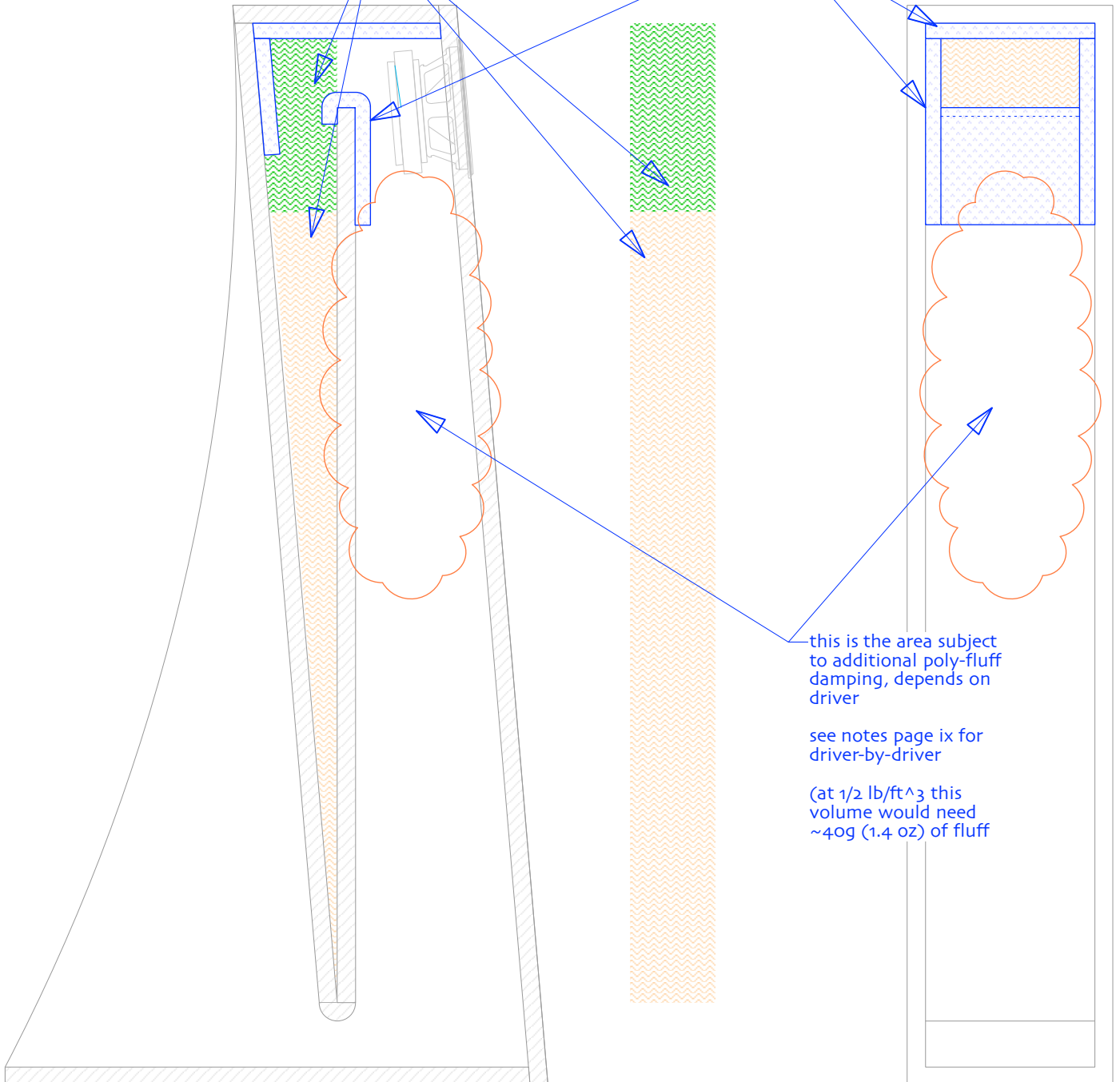

this is the area subject to additional poly-fluff damping, depends on driver

see notes page ix for driver-by-driver

(at 1/2 lb/ft³ this volume would need ~40g (1.4 oz) of fluff

Frugel-Horn Mk3 1v0
sheet D-1 – Side felt template (15mm)

designed by S Lindgren | drawn by did
27-september-2011
© 2010, 2011 Frugal-Horn.com

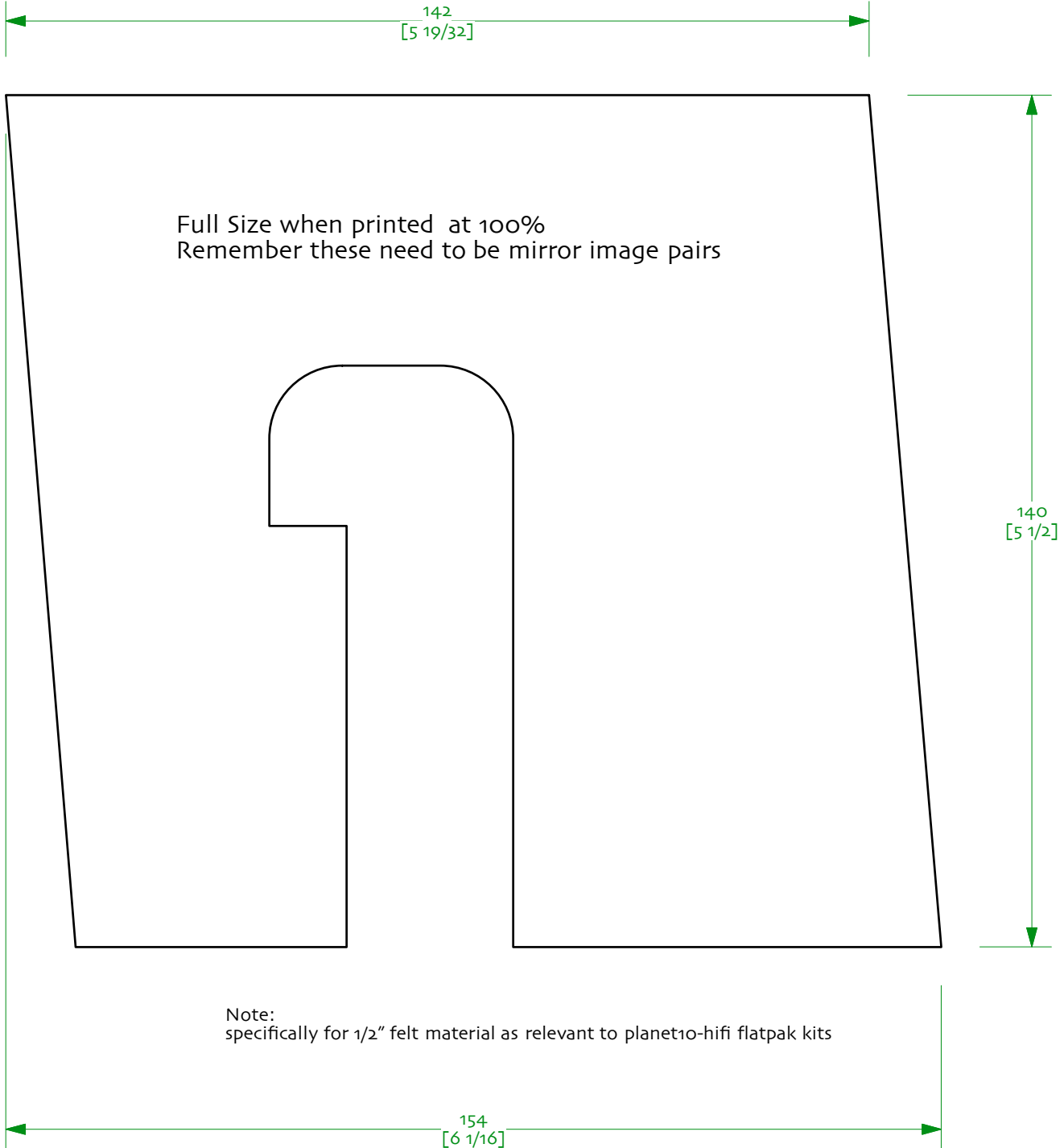

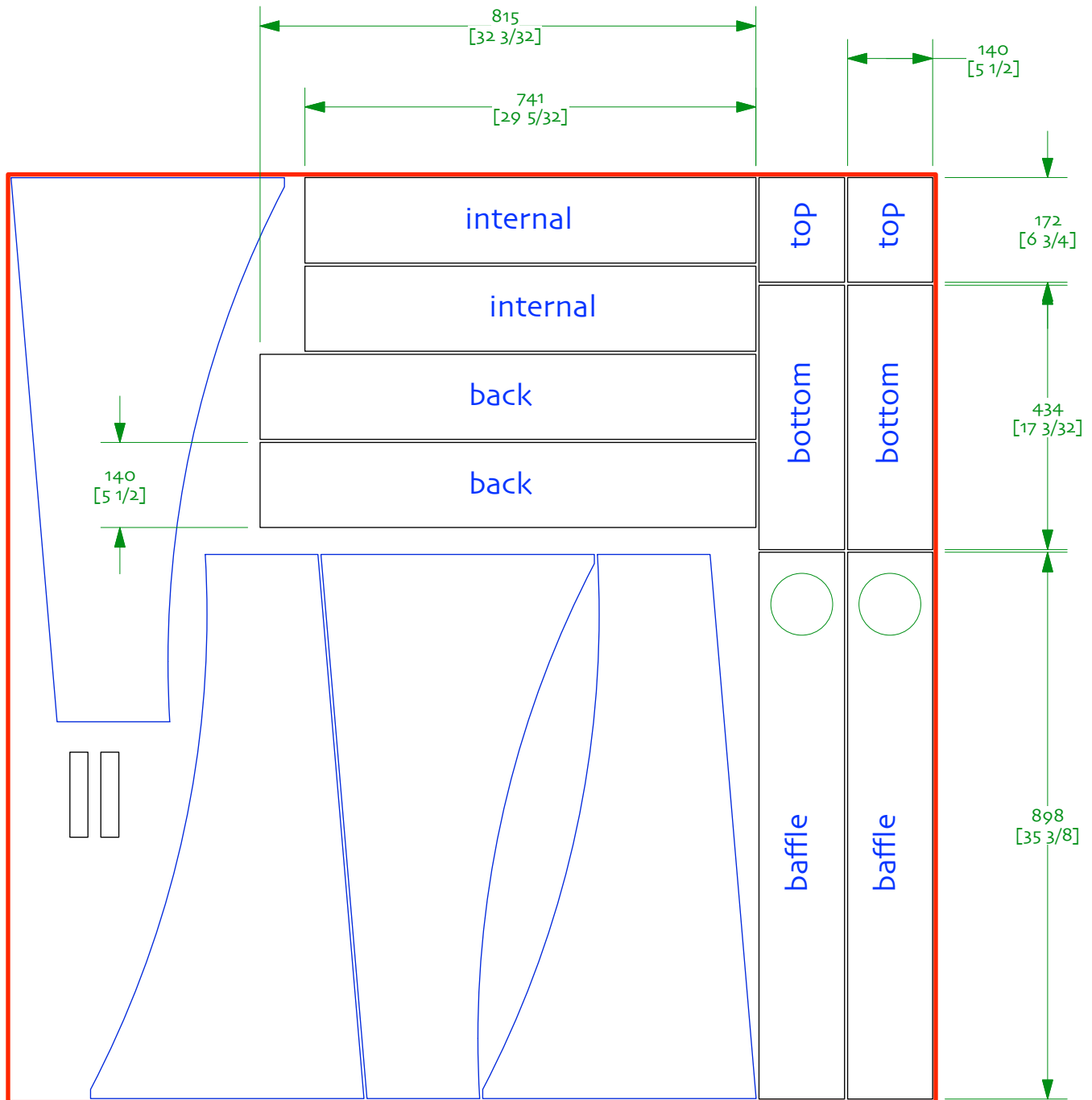

Frugel-Horn Mk3 1v0
 Sheet C-0 – 5x5 15mm cut sheet
 layout by Chris Bobiak
 drawn by dld / 27-sept-2011
 © 2010, 2011 Frugel-Horn.com

Notes:
 1/ 5mm kerf & trim allowance
 2/ very tight cut plan

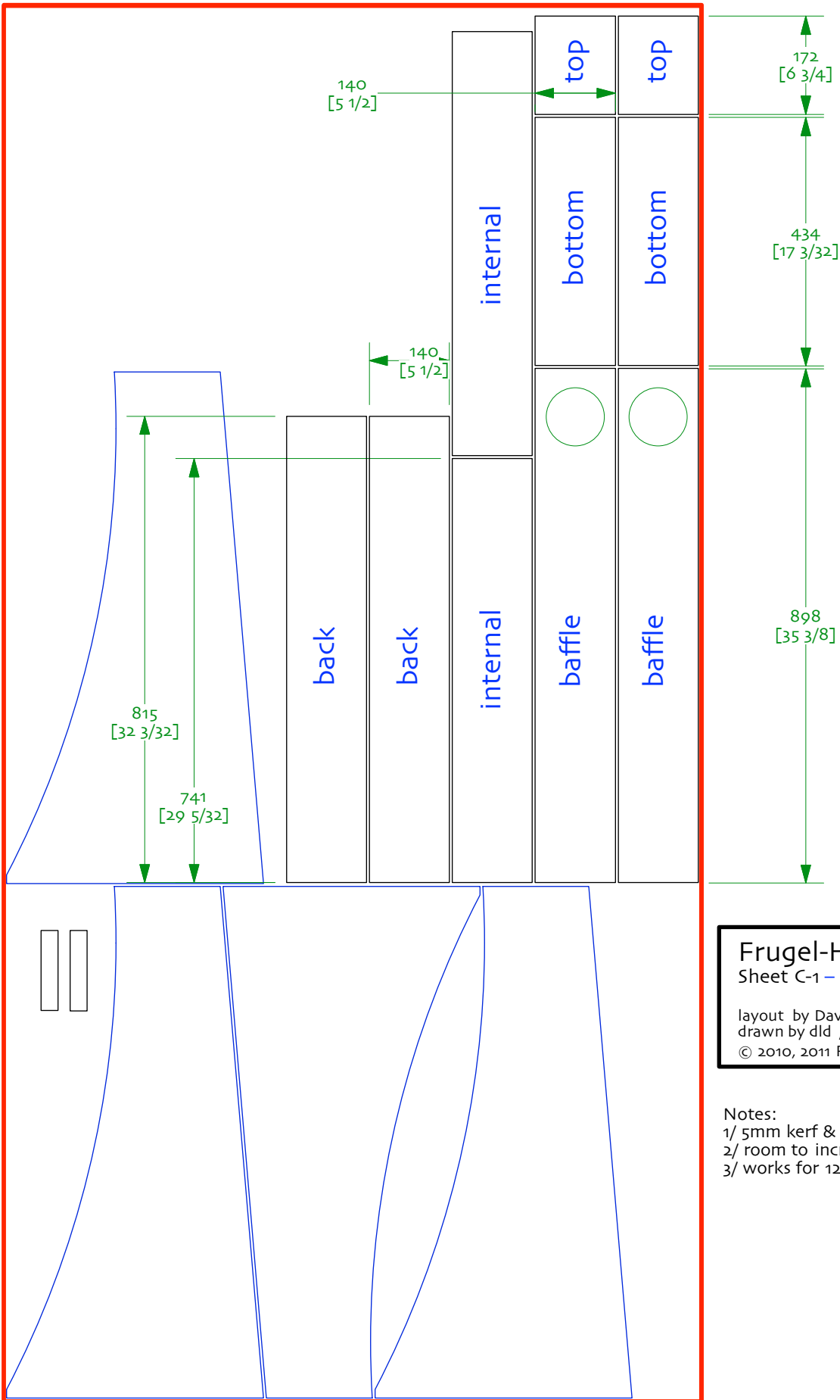

Frugal-Horn Mk3 1v0
 Sheet C-1 – 4x8' 15mm cut sheet

layout by David Dlugos
 drawn by dld / 27-sept-2011
 © 2010, 2011 Frugal-Horn.com

Notes:
 1/ 5mm kerf & trim allowance
 2/ room to increase kerf for CNC
 3/ works for 1220x2440mm sheets

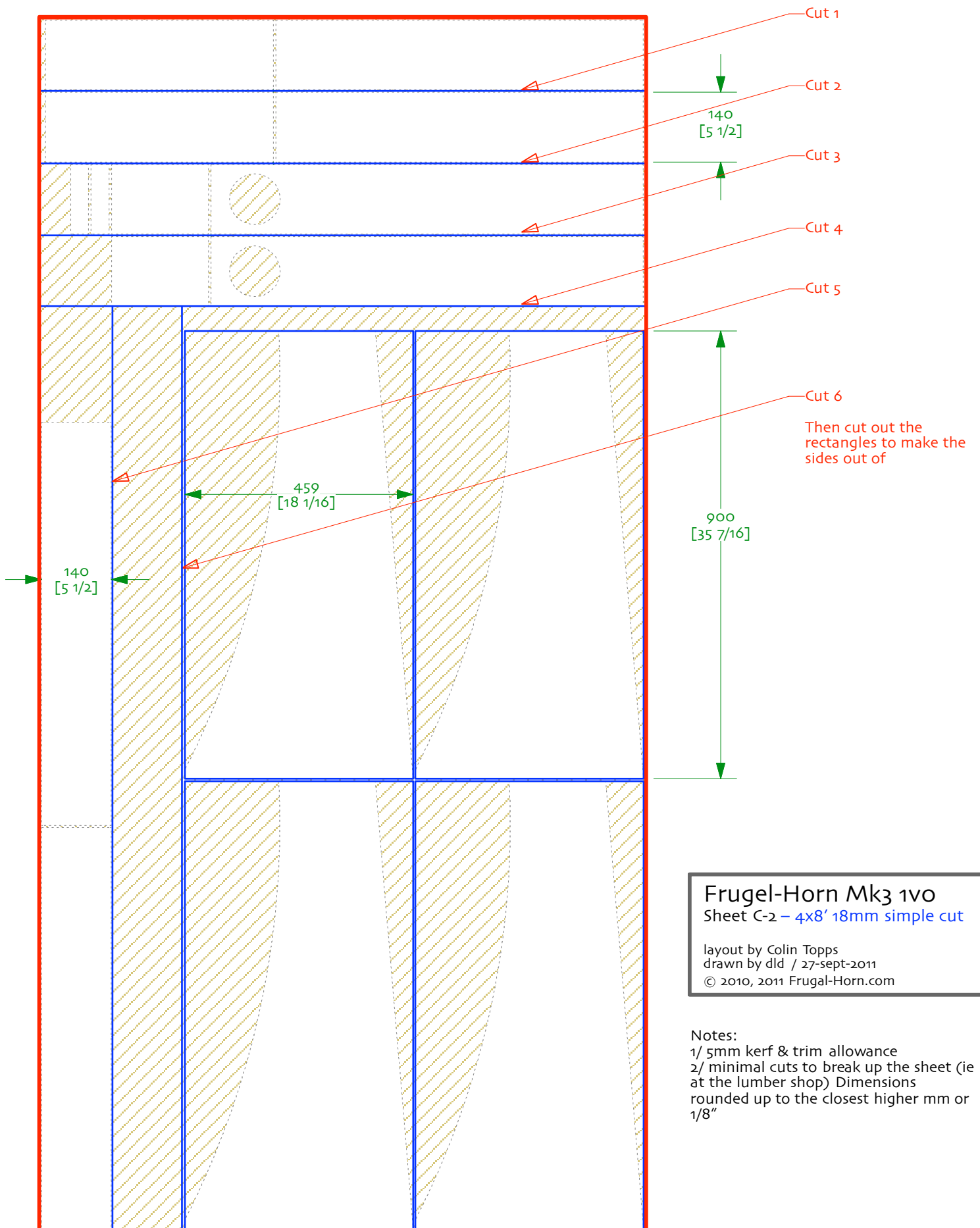

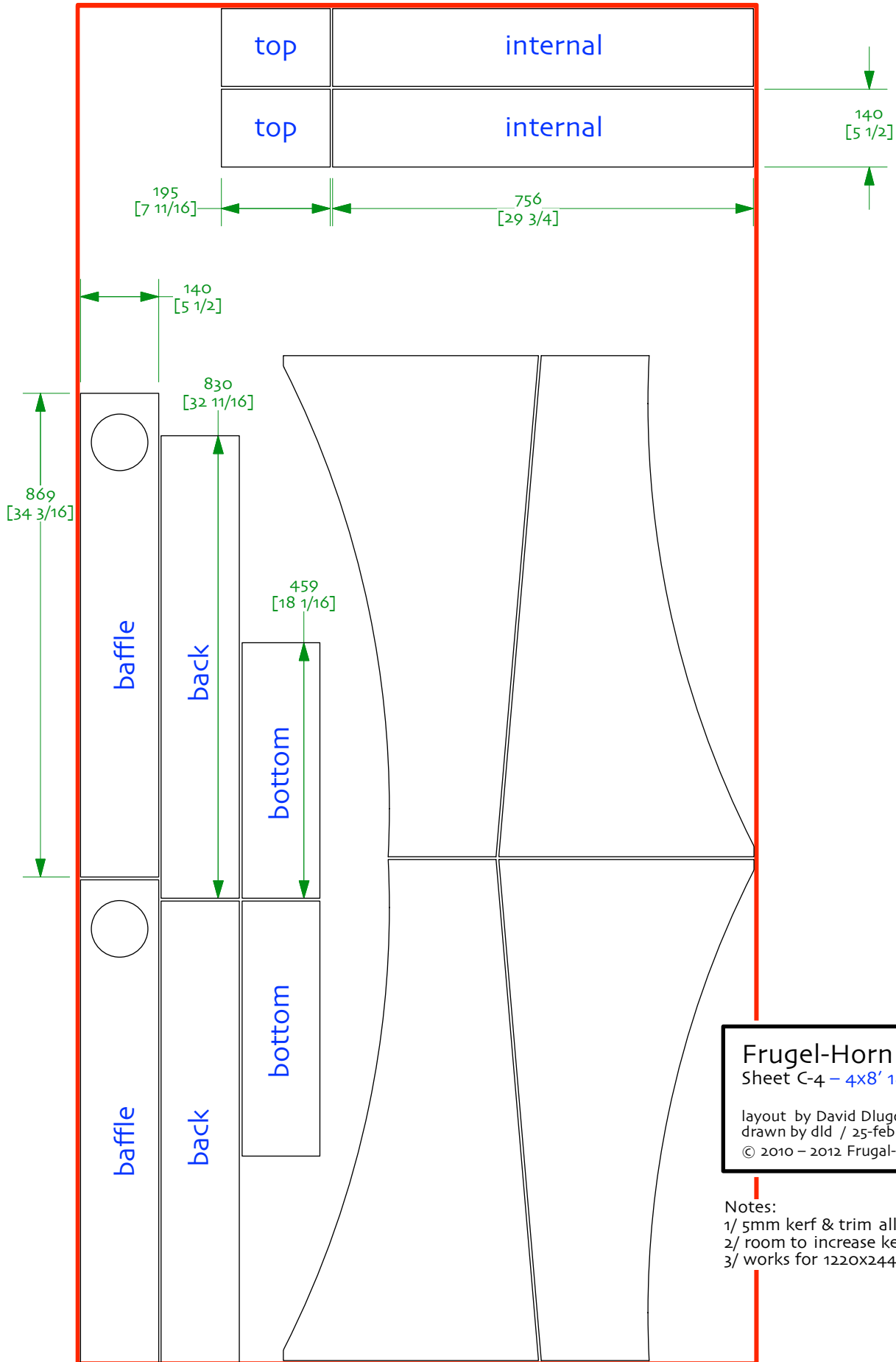

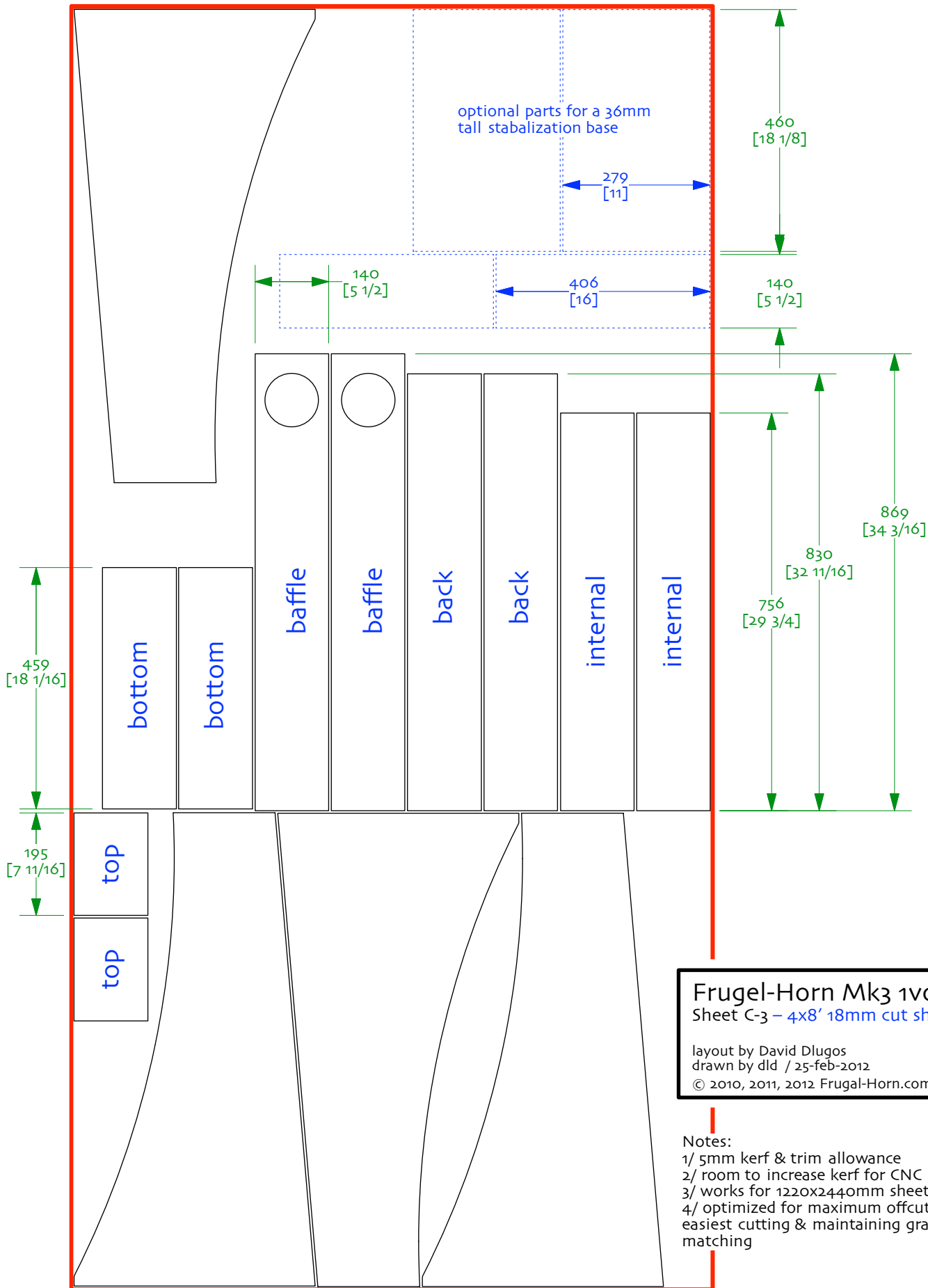

Frugel-Horn Mk3 1v0
 Sheet C-3 – 4x8' 18mm cut sheet

layout by David Dlugos
 drawn by dld / 25-feb-2012
 © 2010, 2011, 2012 Frugel-Horn.com

Notes:
 1/ 5mm kerf & trim allowance
 2/ room to increase kerf for CNC
 3/ works for 1220x2440mm sheets
 4/ optimized for maximum offcut not
 easiest cutting & maintaining grain
 matching

Double Frugel-Horn Mk3 ov8 sheet FH3-x-15mm Plan

designed by S Lindgren | drawn by dld
08-november-2013

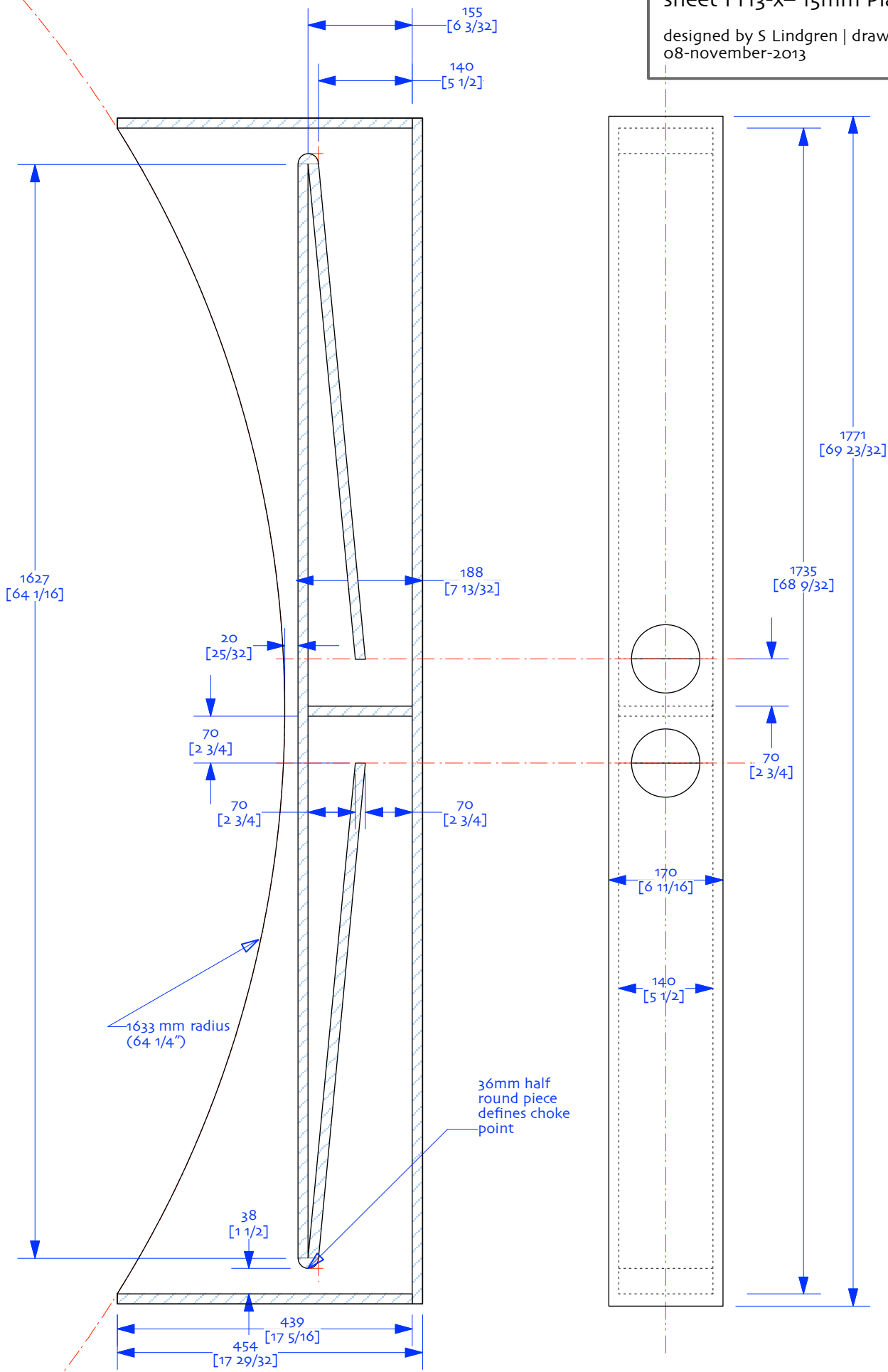

Double Frugel-Horn Mk3 ov8
 sheet FH3-x- 15mm MTM detail
 designed by S Lindgren | drawn by dld
 12-november-2013

Ideal

would require an external curved
 birt to hide back of tweeter.

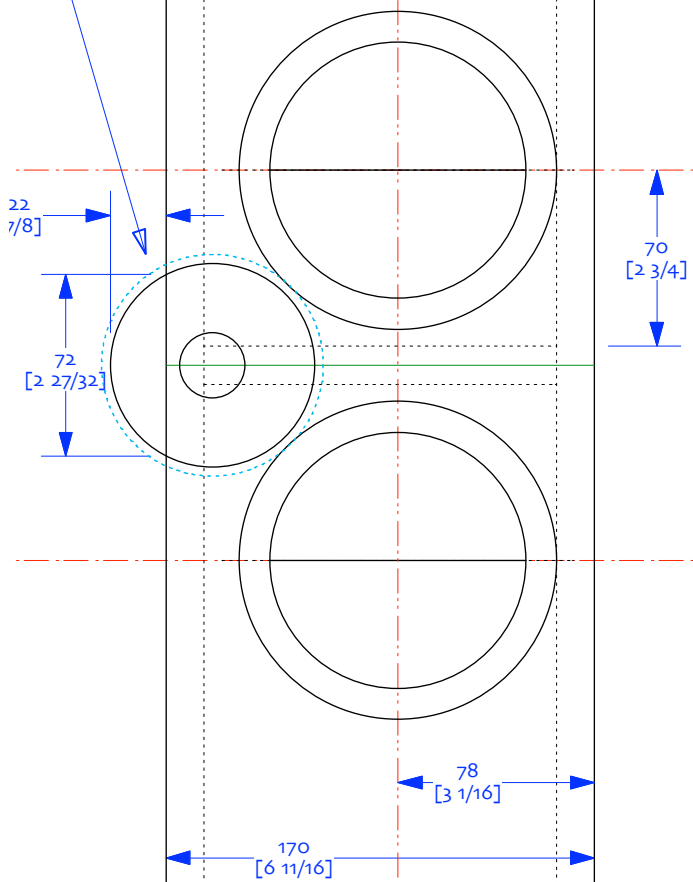

Possible?

too much to try shaping
 the bezel back?

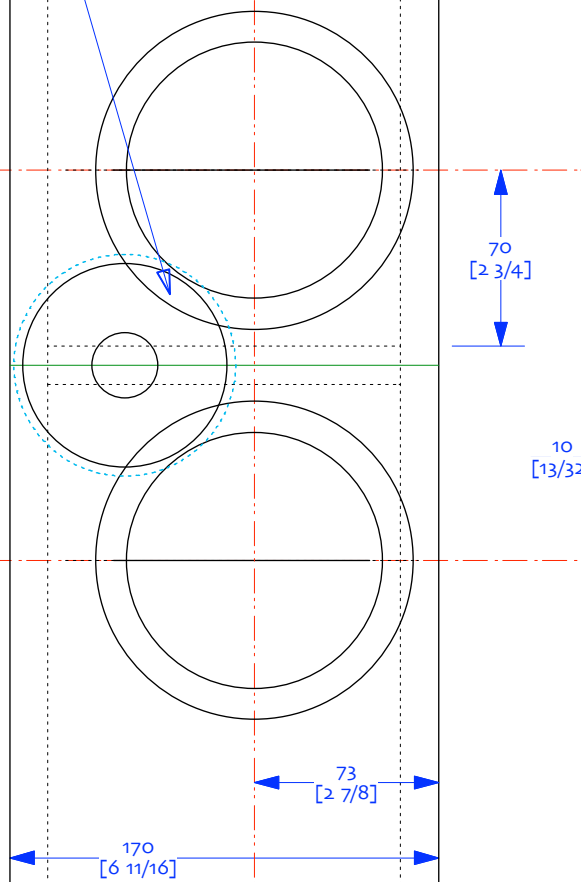

buildability
 compromise

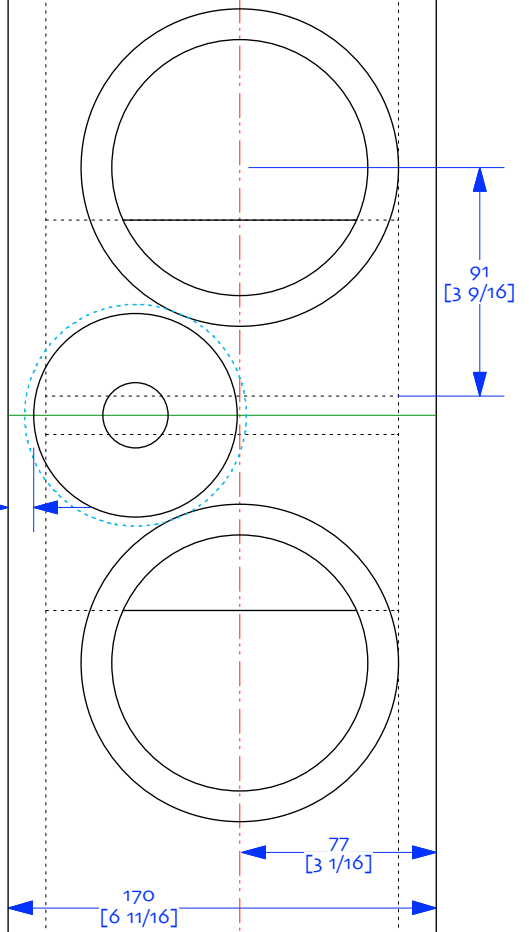

Notes:

- 1/ drawn with 12mm material
- 2/ this design does not go low, designed as a timbre matched centre for FE126En Frugel-Horn Mk3s
- 3/ All internal panels lined with $\sim 1/2$ " (12mm) wool felt (preferred), 1" (25mm) poly-fluff batting, or $3/4$ " (19mm) fiberglass Note that it is hard to get into the box after it is sealed up. Do not occlude vent opening.

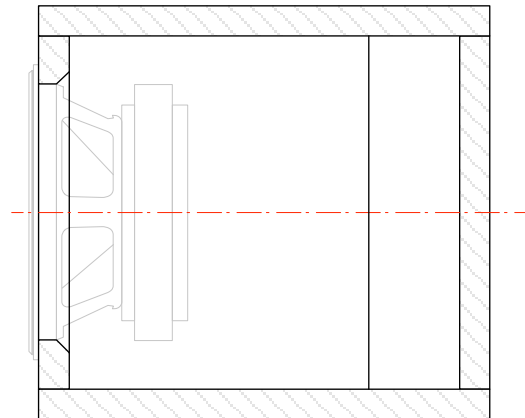
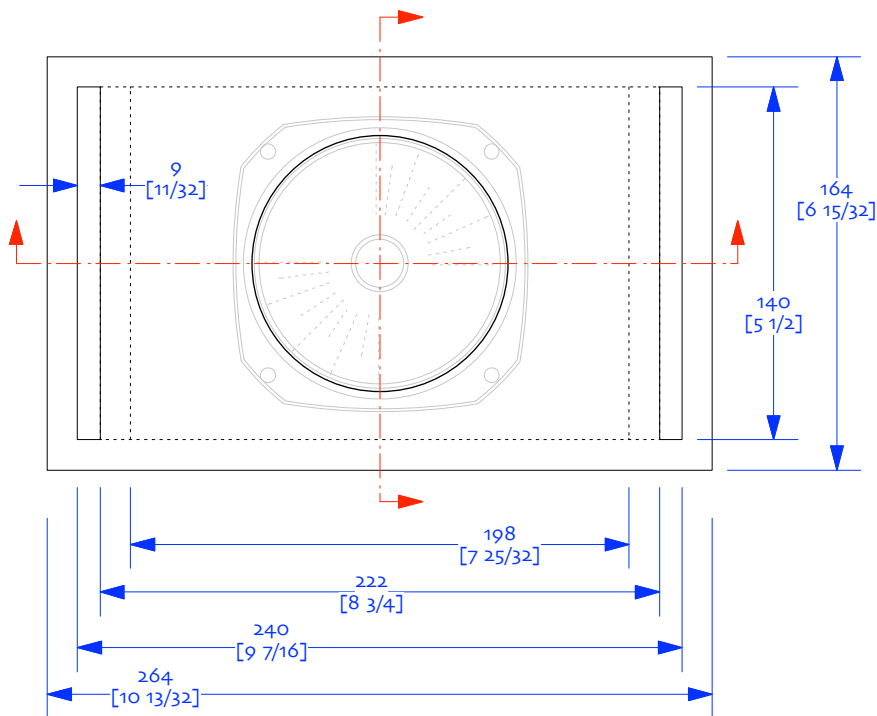
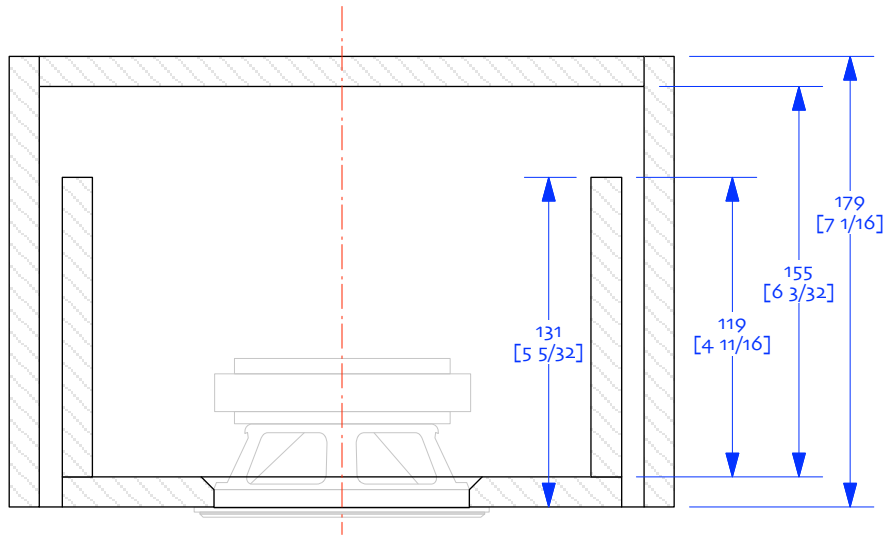
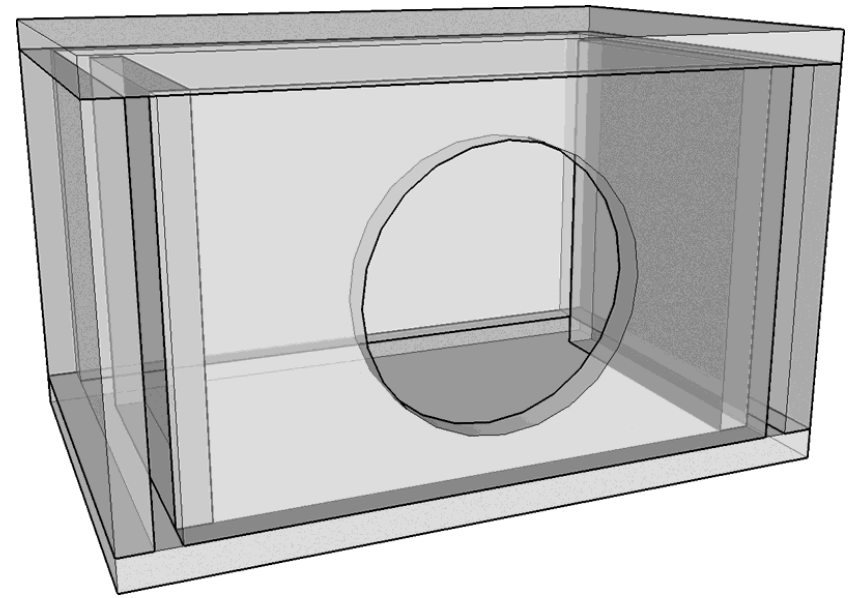

FE126En Centre
sheet Aux-o – 12mm Plan

designed by & drawn by D Dlugos
03-november-2011

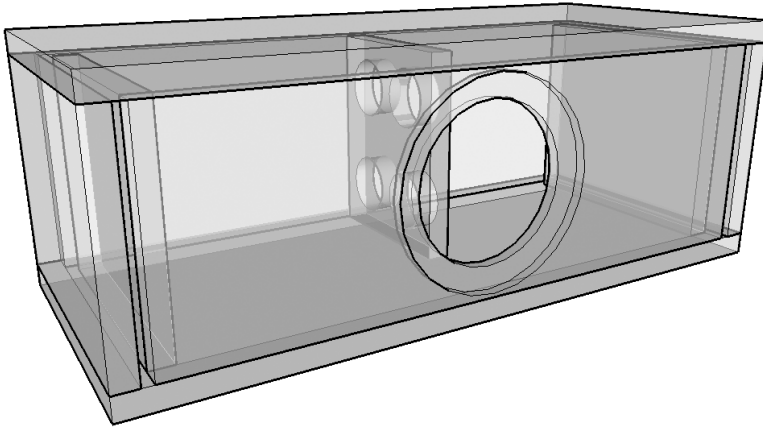

Alpair 7.3 dMar-Ken7.3a Centre ov93

sheet xx | plan (15mm)
03-june-2013 designed & drawn by dld
© 2011-2013 planet_10 enterprises limited
for licenced use only

Notes:

to Subscribers: Centre channel enclosures have special constraints related to available space as near the display screen as possible (generally immediately below or above). This centre is designed for minimum height and minimum depth (without introducing more complex vents). If you have other specific requirements, contact me and i'll morph the design to more closely fit your needs. For installations needing a smaller box, there is the slightly smaller cMarS Centre (not drawn as of this note) and considerably smaller Alpair6m (coming soon)

- o/ designed for Mark Audio Alpair7.3
- 1/ All panels 15mm thick
- 2/ walls lined with 1/2" (12mm) cotton or wool felt. Centre side of holey brace lined with lower density felt or poly batting

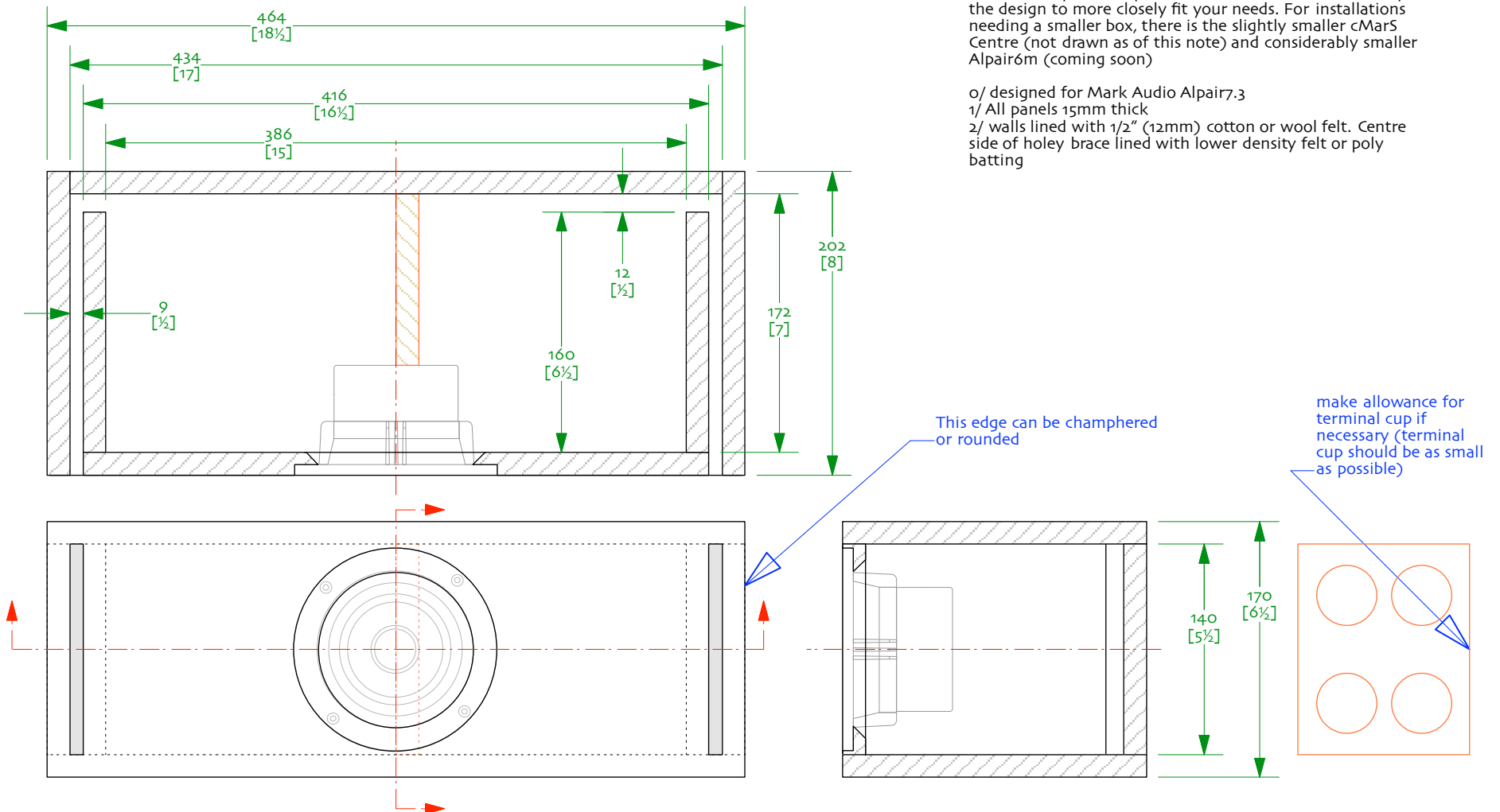

Fostex FF125wk dFonken125 CentreA ov82

sheet xx | plan (15mm)
 23-november-2015 designed & drawn by dld
 © 2011-2015 planet_10 enterprises limited
 free for non-commercial use only

Notes:

to Subscribers: Centre channel enclosures have special constraints related to available space as near the display screen as possible (generally immediately below or above). This centre is designed for minimum height and minimum depth (without introducing more complex vents). If you have other specific requirements, contact me and i'll morph the design to more closely fit your needs. For installations needing a smaller box, there is the slightly smaller cMarS Centre (not drawn as of this note) and considerably smaller Alpair6m (coming soon)

o/ designed for Fostex FF125wk

1/ All panels 15mm thick

2/ walls lined with 1/2" (12mm) cotton or wool felt. Centre side of holey brace lined with lower density felt of poly batting

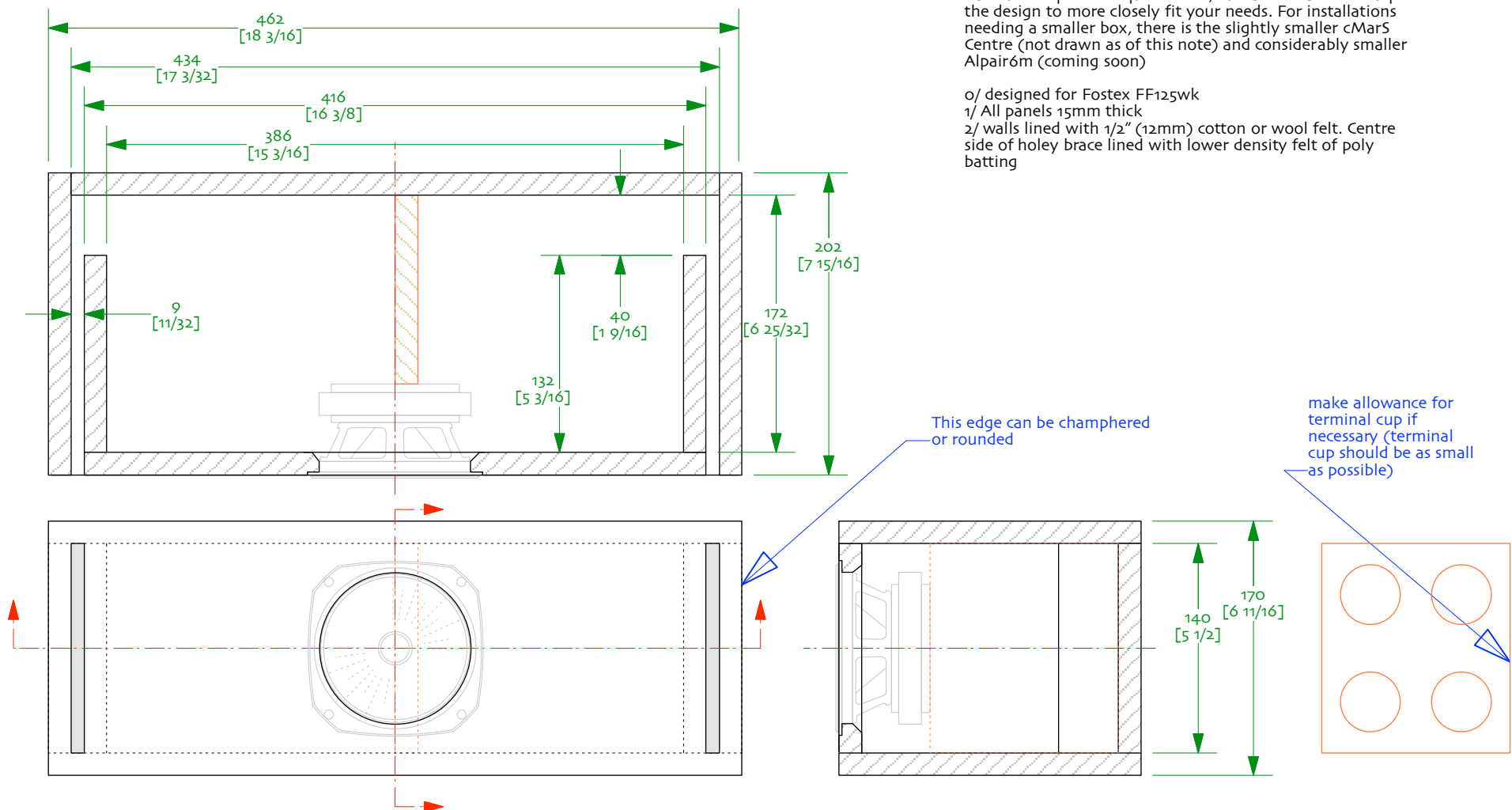

Centre A Mar-Kel70 ov9

CSS EL70 | 15mm

© 2011-2012 planet_10 enterprises limited
 18- februaet-2012 | designed & drawn by did
 free for non-commercial use only

Notes:

- o/ A centre channel based derivative of the Mar-Kel70 designed for modified Creative Sound/Mark Audio EL70, will work well with stock driver
- 1/ All panels 15mm
- 2/ brace shape is only suggestive – prime purpose is to brace driver, it needs to be about 35-40% holes. (ie if you have to mount a terminal cup in the middle, you'll want to make sure the brace allows clearance), it is centrally mounted on the driver magnet
- 3/ Don't forget to angle cut the back of the driver cut-out to give it breathing room
- 4/ All internal panels lined with ~1/2" (12mm) cotton or wool felt (preferred), 3/4" (19mm) poly-fluff batting, or 1" (25mm) fiberglass Note that it is hard to get into the box after it is sealed up (means terminals need to be solderable from outside the box as well)

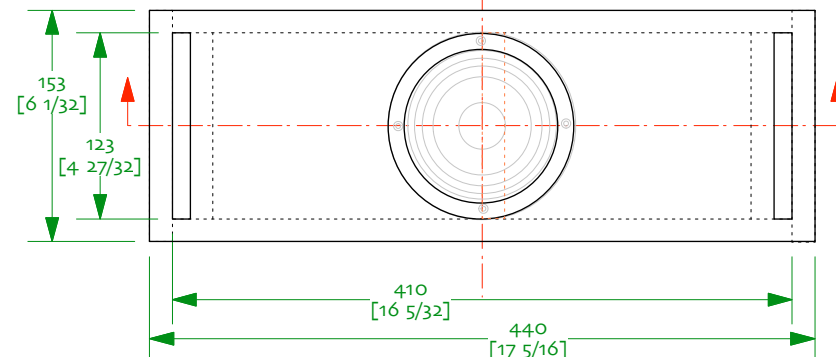
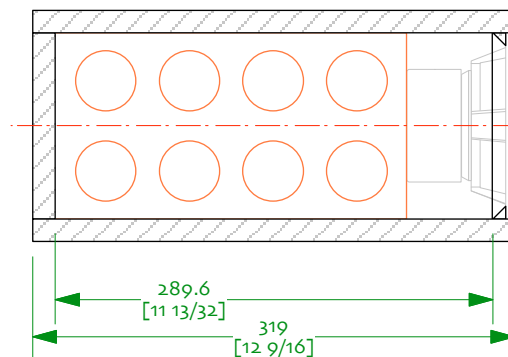
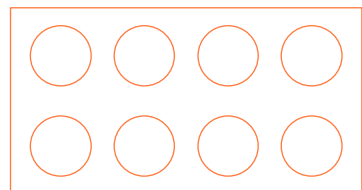
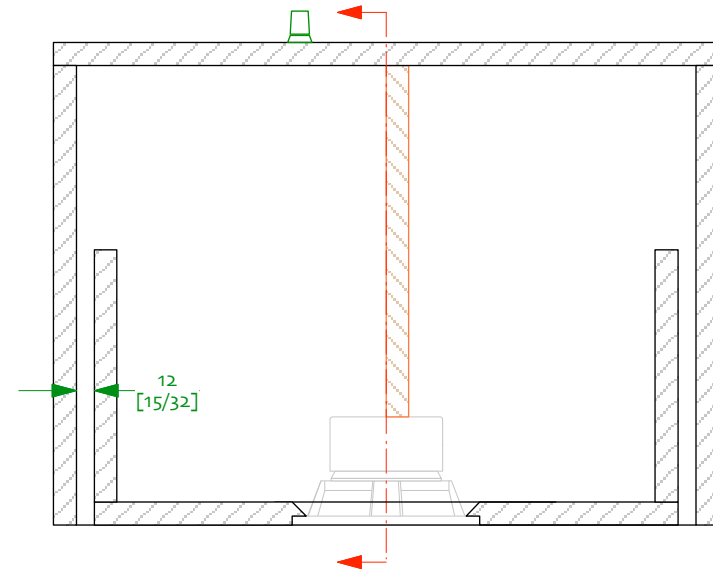

Alpair 7 dMar-Ken7a Centre 1v01

sheet xx | plan (15mm)

17-september-2011 designed & drawn by dld

© 2011 planet_10 enterprises limited | for licenced use only

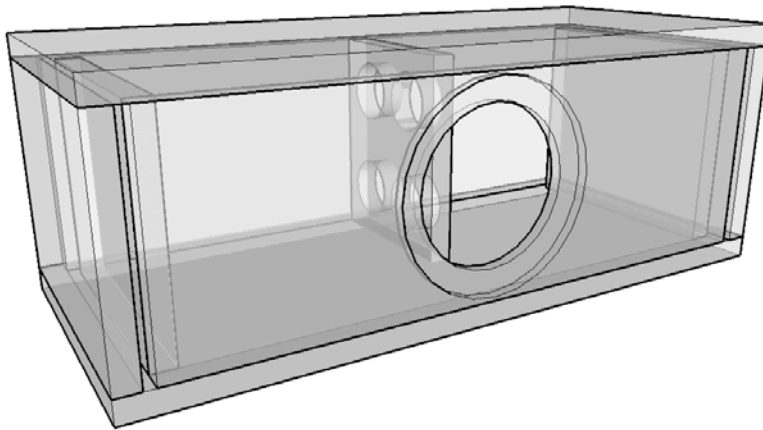

Notes:

to Subscribers: Centre channel enclosures have special constraints related to available space as near the display screen as possible (generally immediately below or above). This centre is designed for minimum height and minimum depth (without introducing more complex vents). If you have other specific requirements, contact me and i'll morph the design to more closely fit your needs. For installations needing a smaller box, there is the slightly smaller cMarS Centre (not drawn as of this note) and considerably smaller Alpair6m (coming soon)

o/ designed for Mark Audio Alpair7

1/ All panels 15mm thick

2/ walls lined with 1/2" (12mm) cotton or wool felt. Centre side of holey brace lined with lower density felt of poly batting

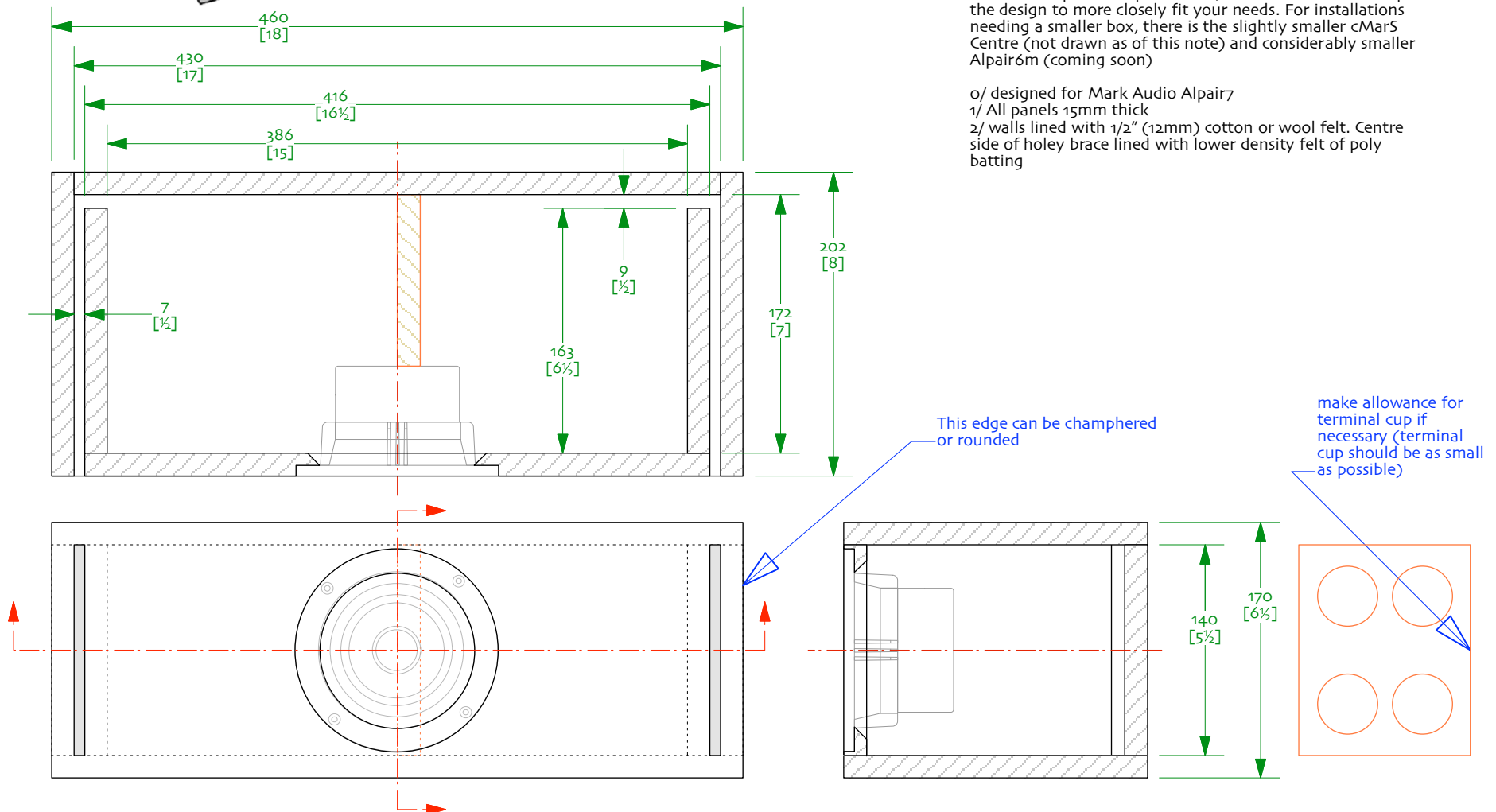

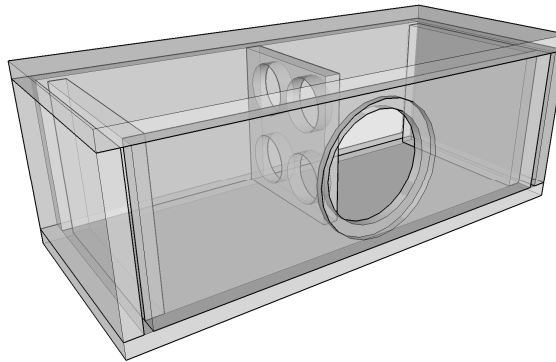
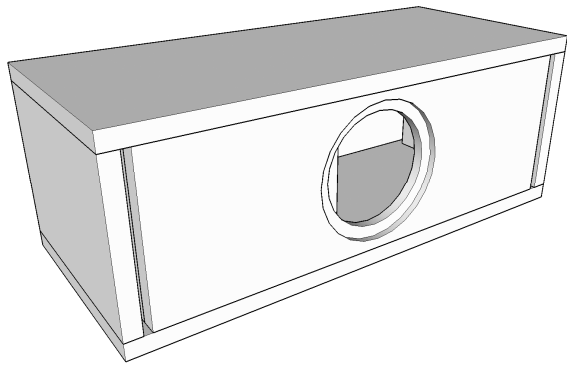

CHR70 (any) dCHR-Ken70a Centre 1vo
sheet xx | plan (15mm)
16-february-2012 designed & drawn by dld
© 2011-2012 planet_10 enterprises limited
for noncommercial use only

Notes:

- 0/ designed for Mark Audio CHR70/70.2/70.3
- 1/ All panels 15mm thick
- 2/ walls lined with 1/2" (12mm) cotton or wool felt. Centre side of holey brace lined with lower density felt of poly batting

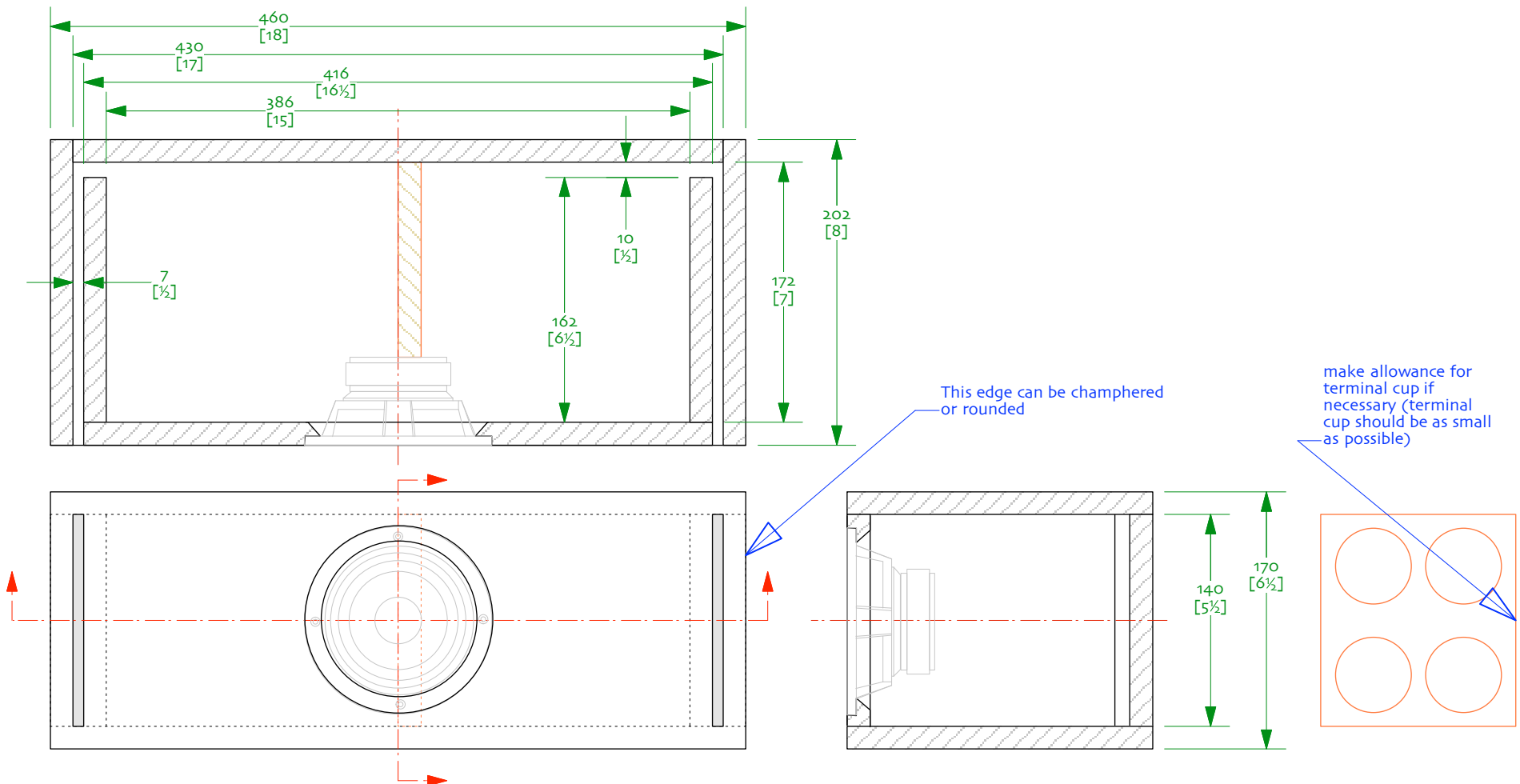



Alpair 7.3
All Parts
driver dimensions
drawn by dld | 06-may-2018

bezel cover

Gasket compresses to ~1.5mm with appropriate pressure

use with single magnet or added a 2nd with magnet cover

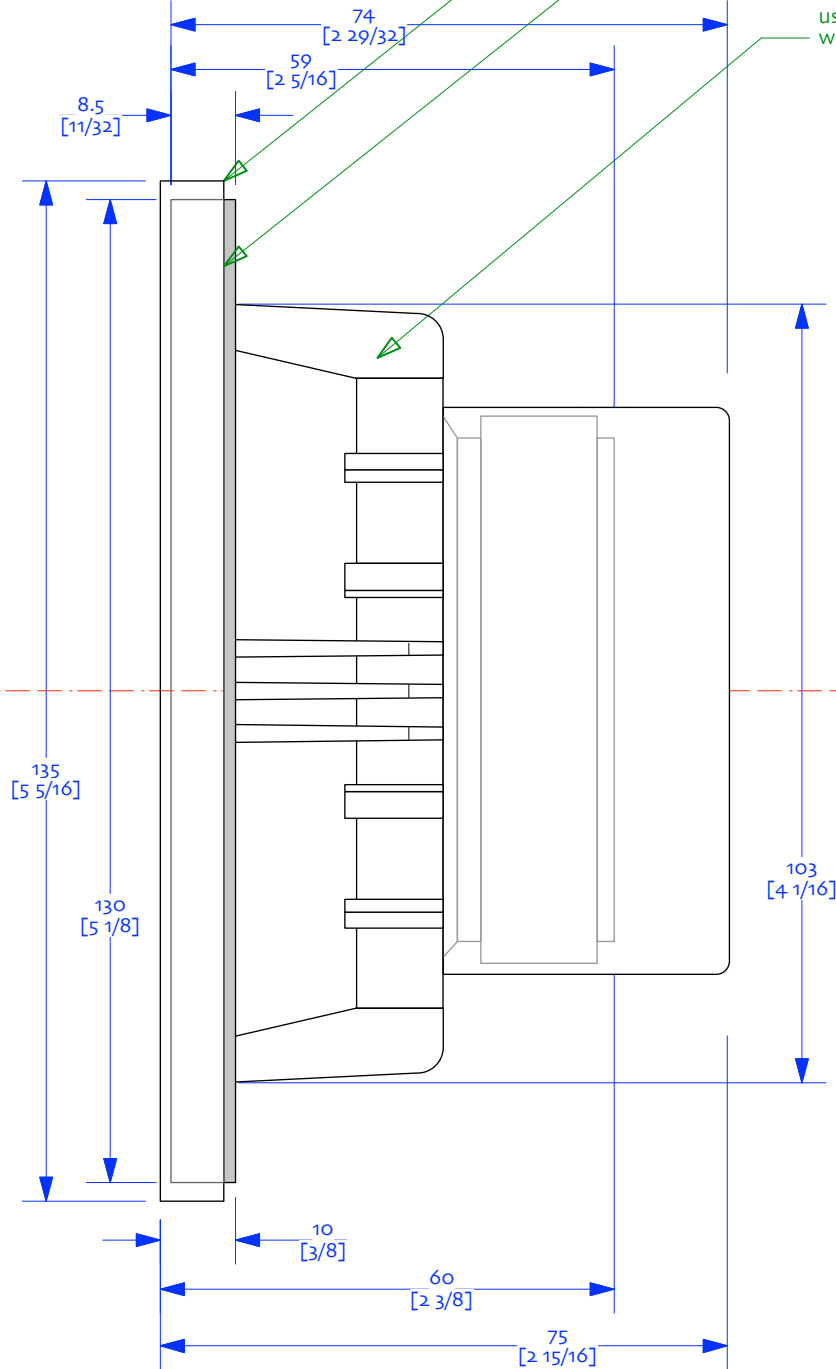

Ø115
[Ø4 17/32]

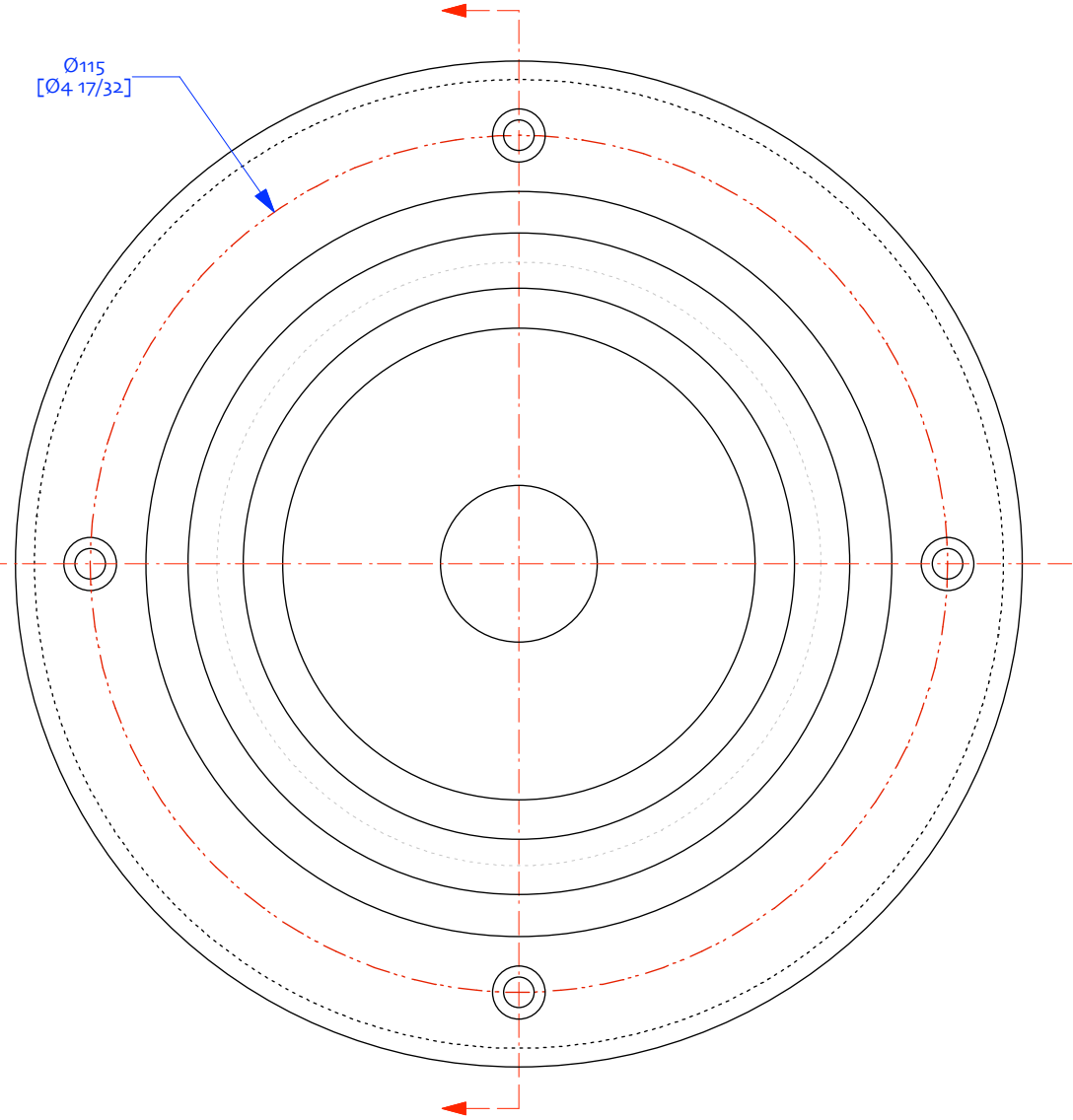

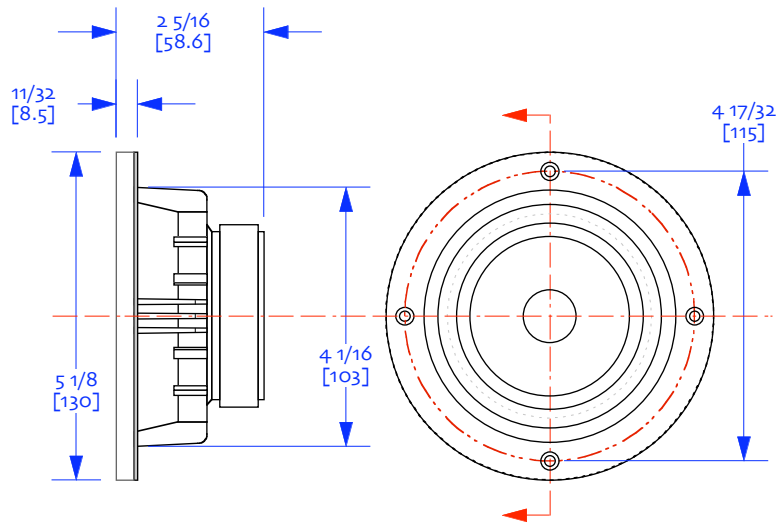

A: 1 magnet / no bezel cover

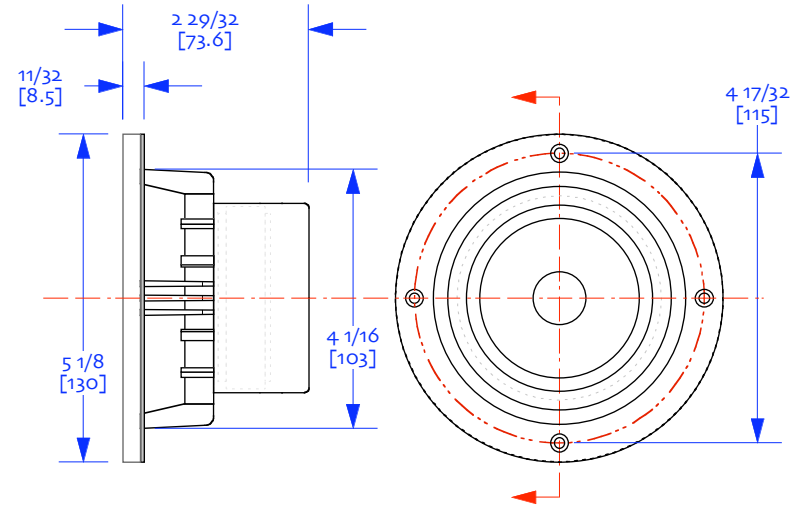

B: 2 magnets / no bezel cover

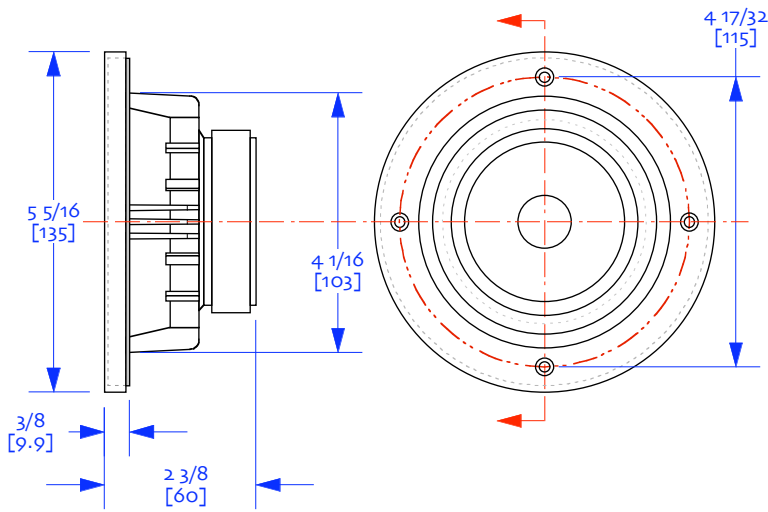

C: 1 magnet / bezel cover

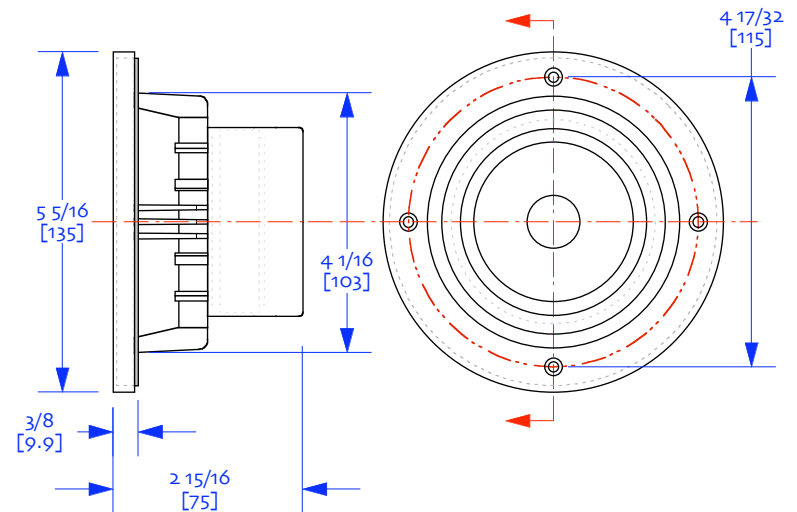

D: 2 magnets / bezel cover



Alpair 7.3
4 possibilities
driver dimensions
drawn by did | 23-june-2011

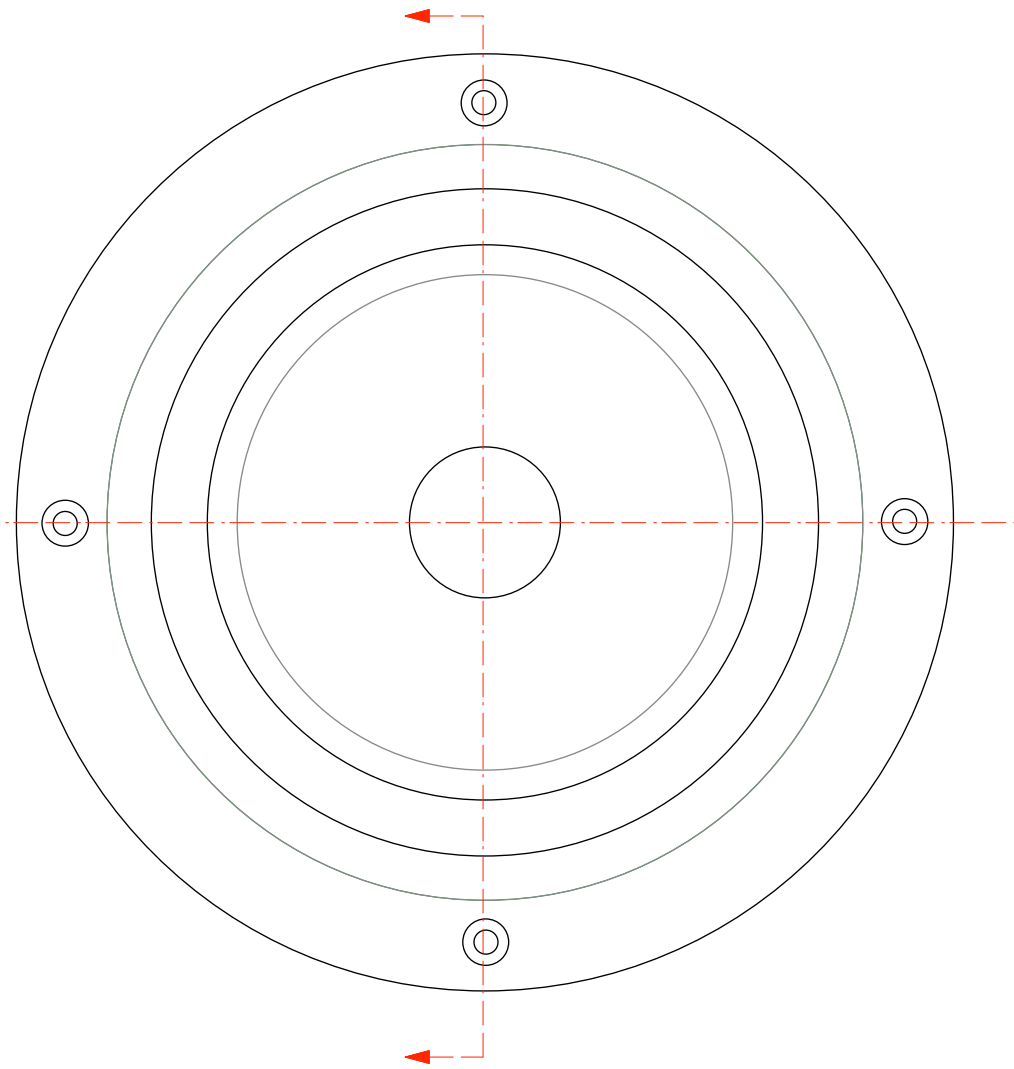
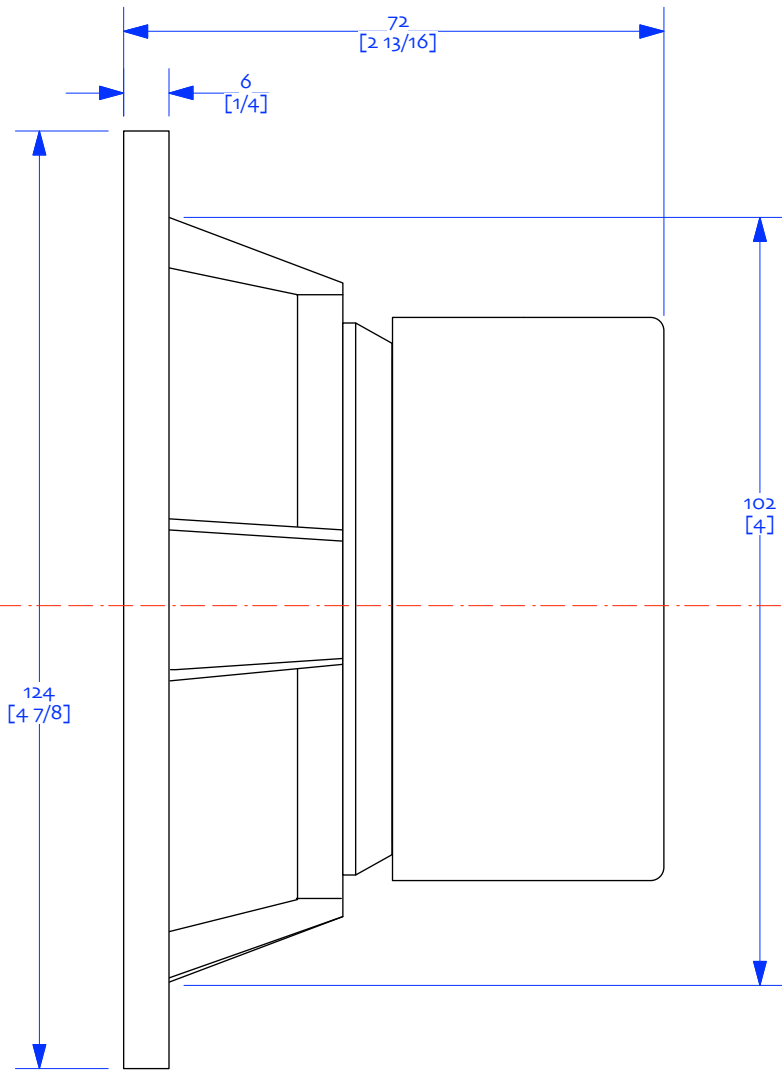



Notes:
 1/ same basket as CHR/CHP-70 but has a double magnet with cover

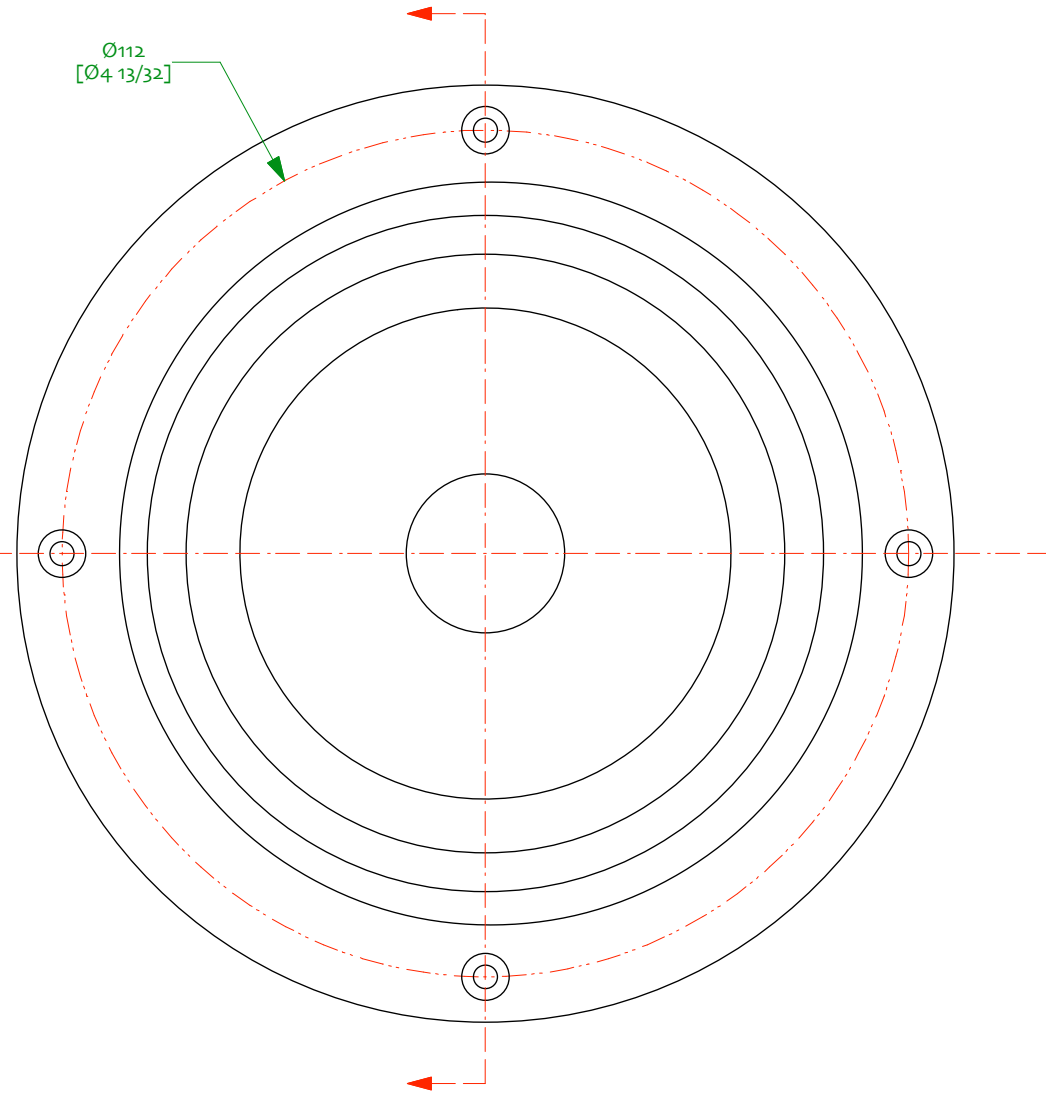
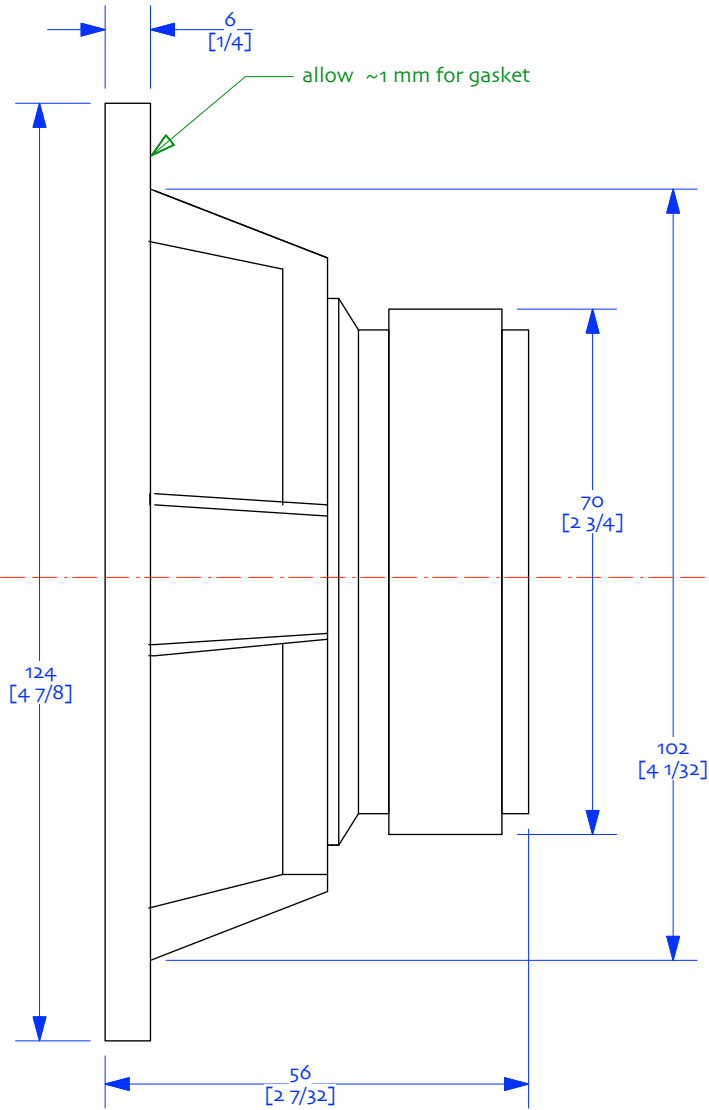

EL70 extended range driver dimensions

drawn by dld | 06-may-2018

CHR-70.3
 CHP-70.2
 CHBW-70
 driver dimensions
 drawn by dld | 06-may-2018

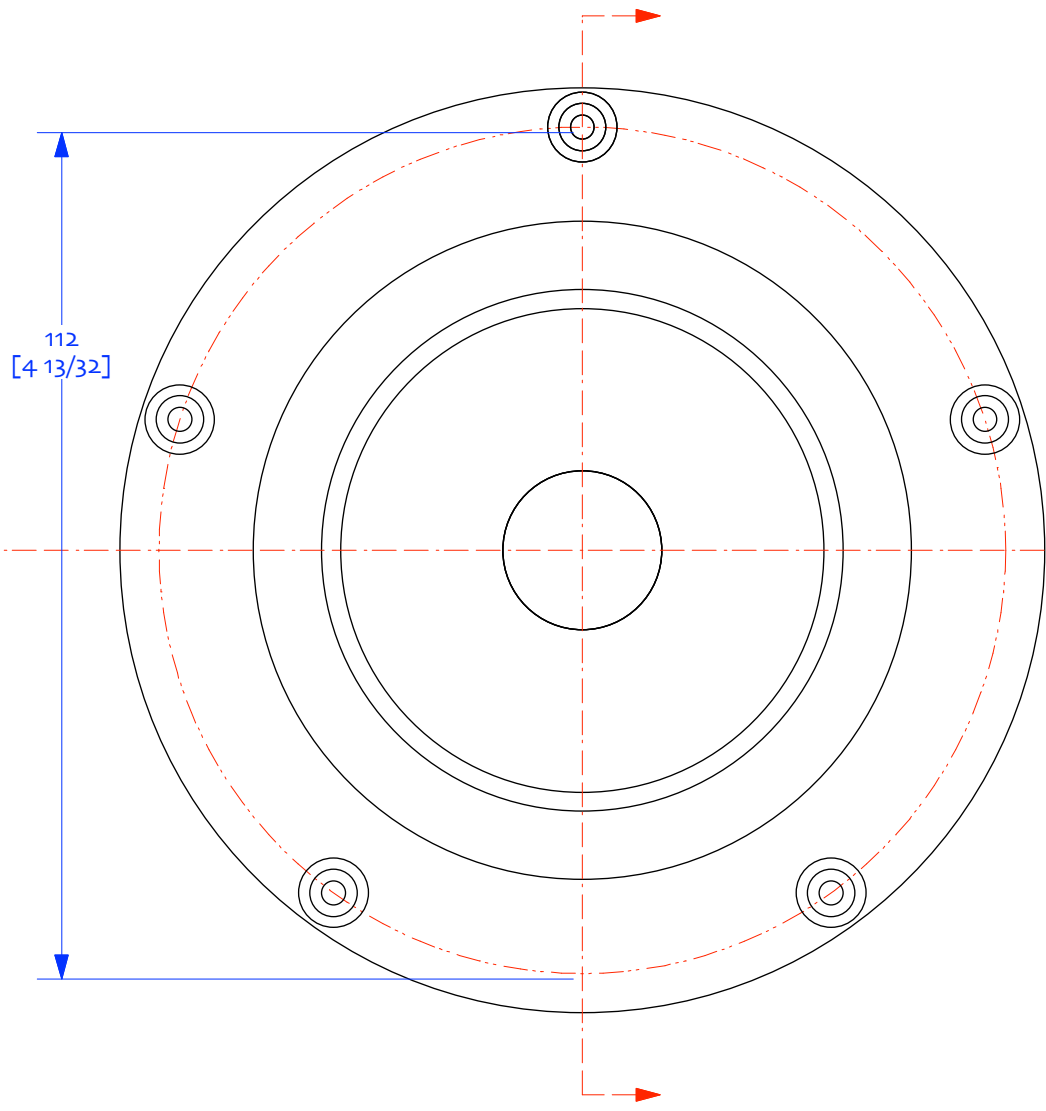
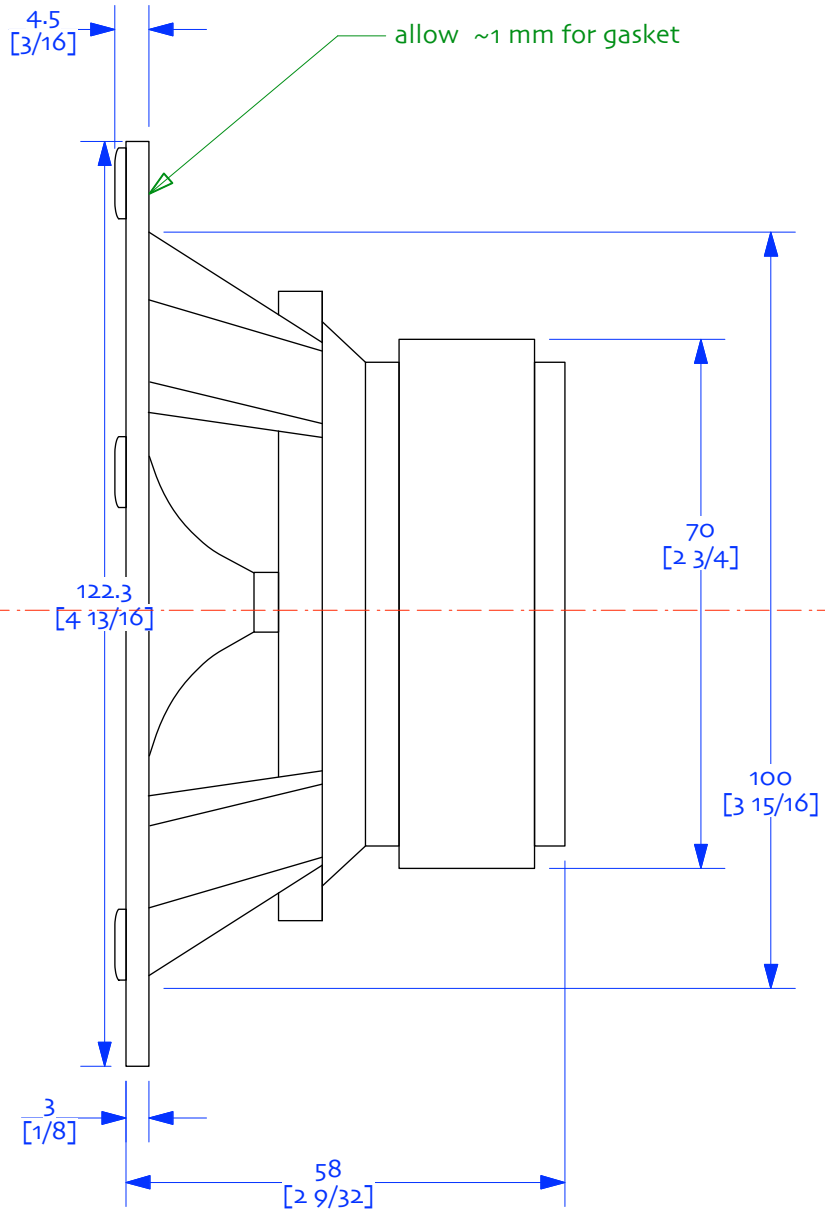

Pluvia Seven / CHS-70
 driver dimensions
 drawn by dld | 14-november-2017

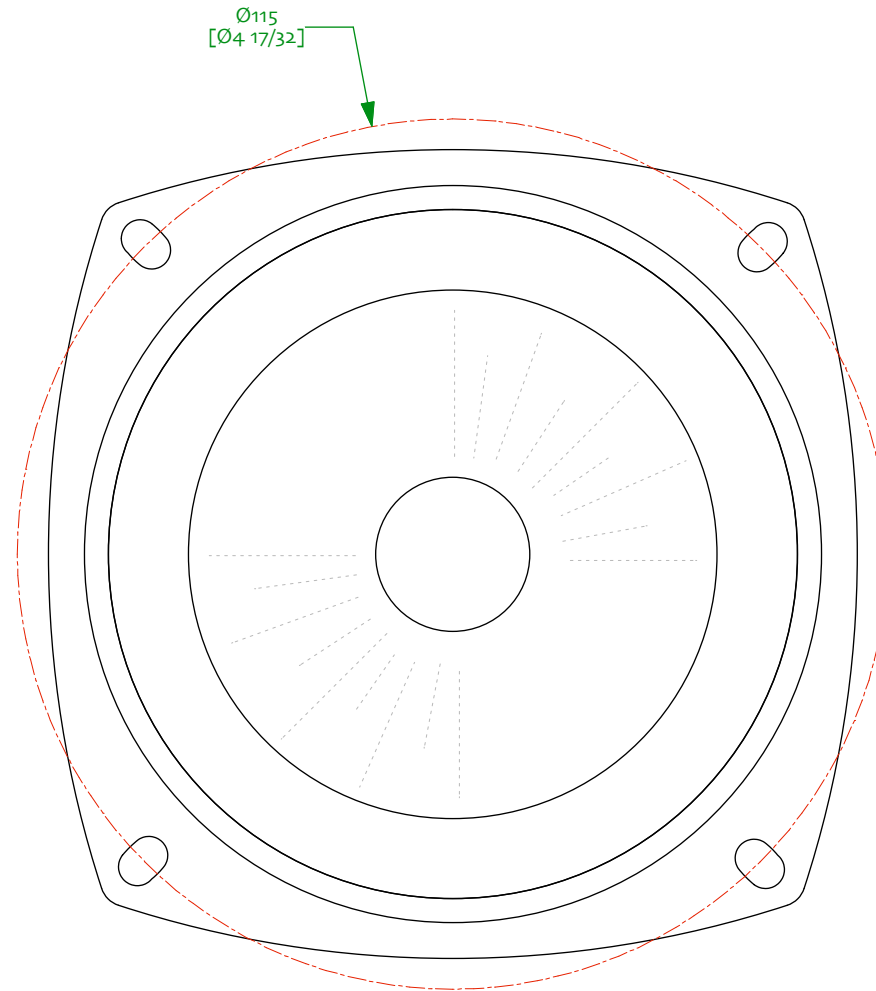
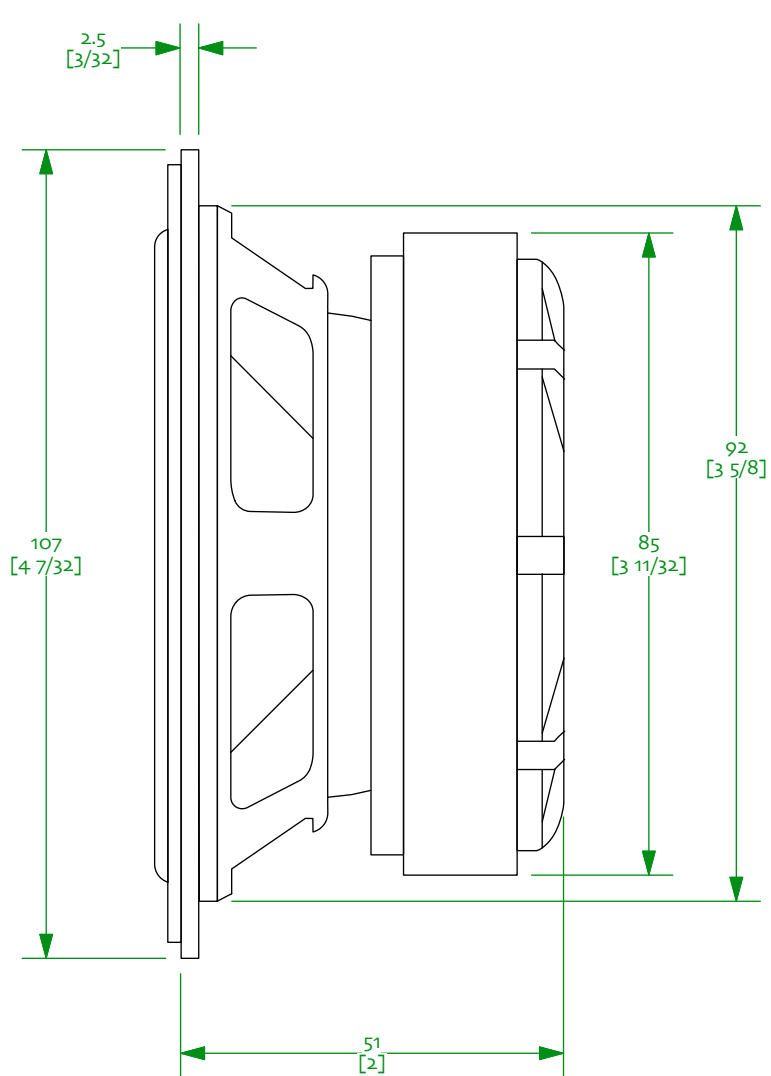

Fostex FF105wk

Dimensions ov91

19-april-2018 | drawn by D Dlugos

© 2009-2018 planet_10 enterprises limited
for licenced use only

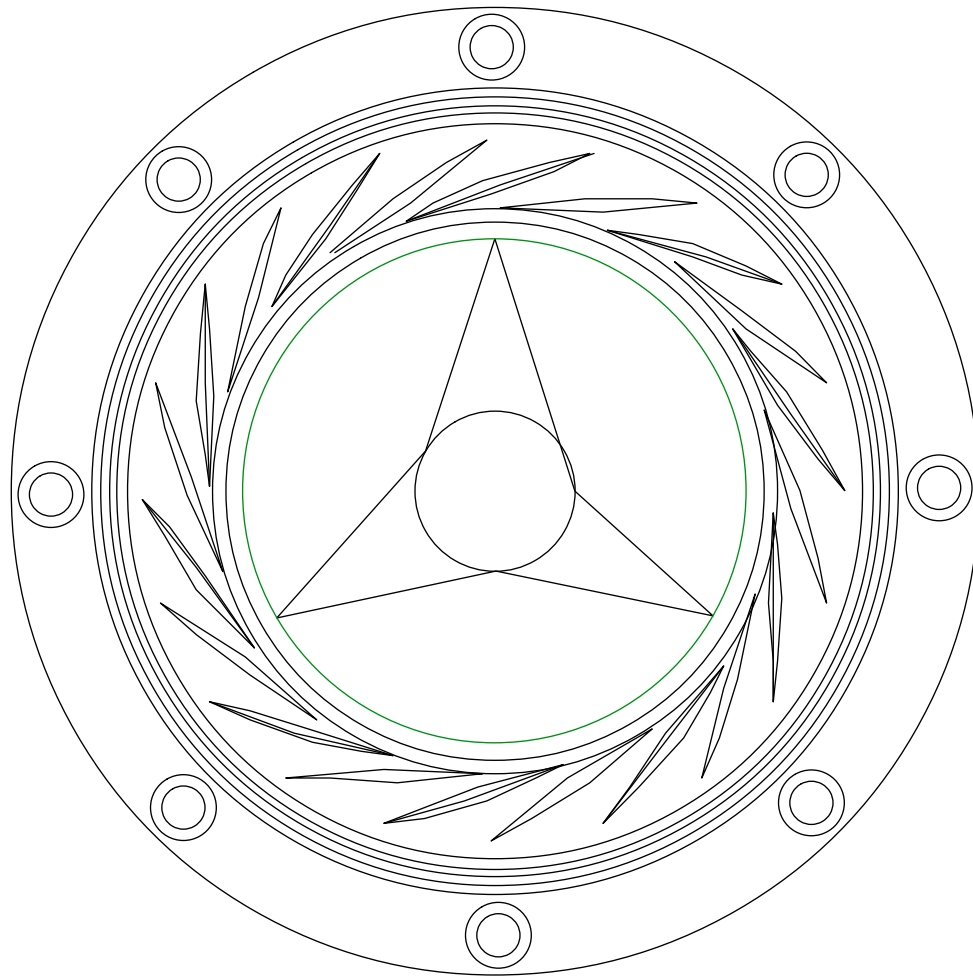
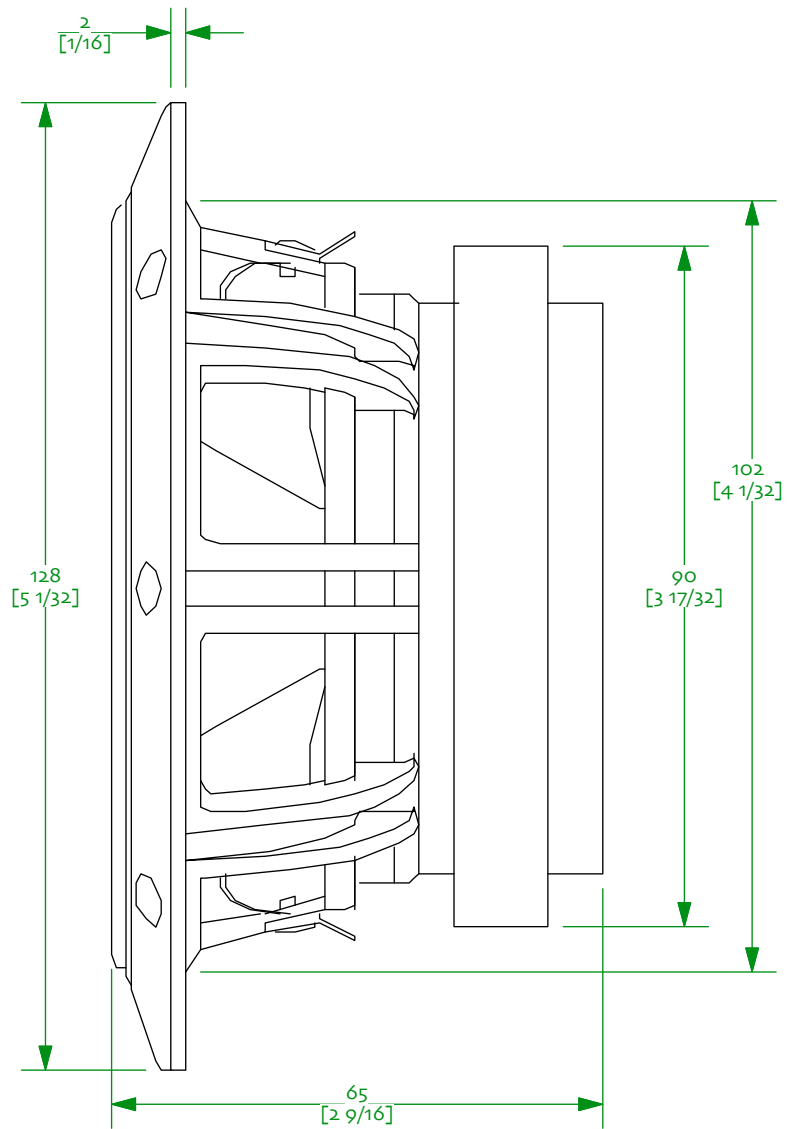

Fostex FE108eΣ

Dimensions ov92

19-april-2018 | drawn by D Dlugos

© 2009-2018 planet_10 enterprises limited
for licenced use only

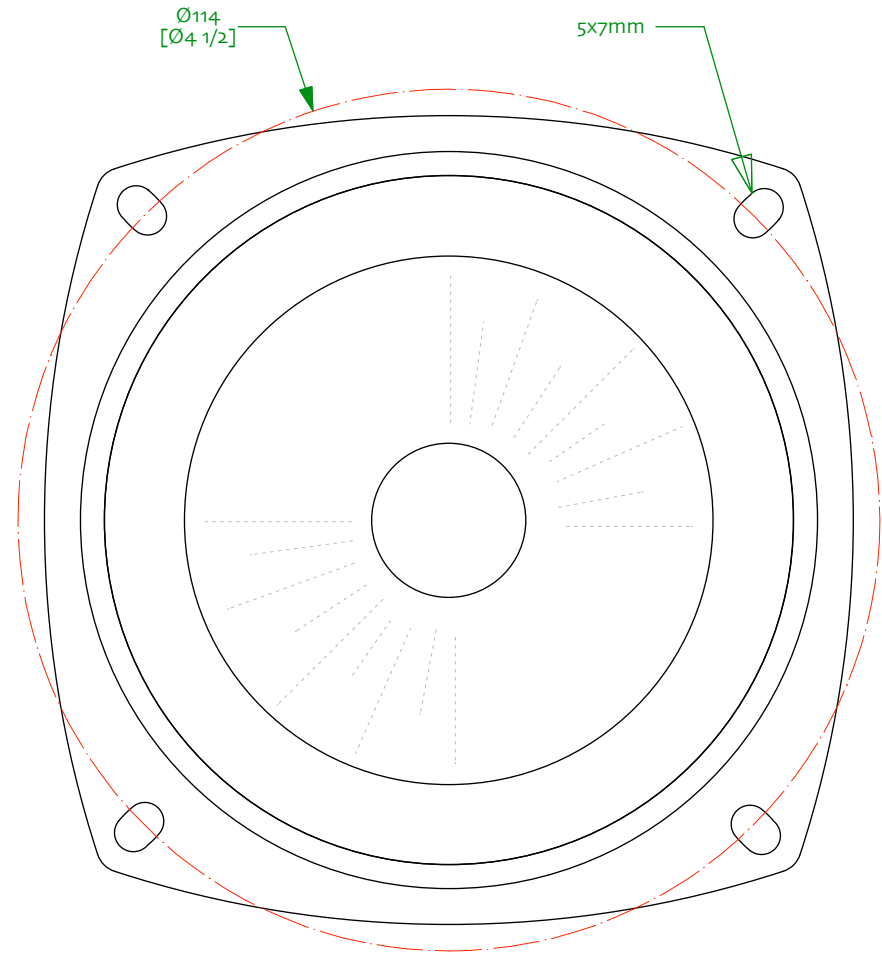
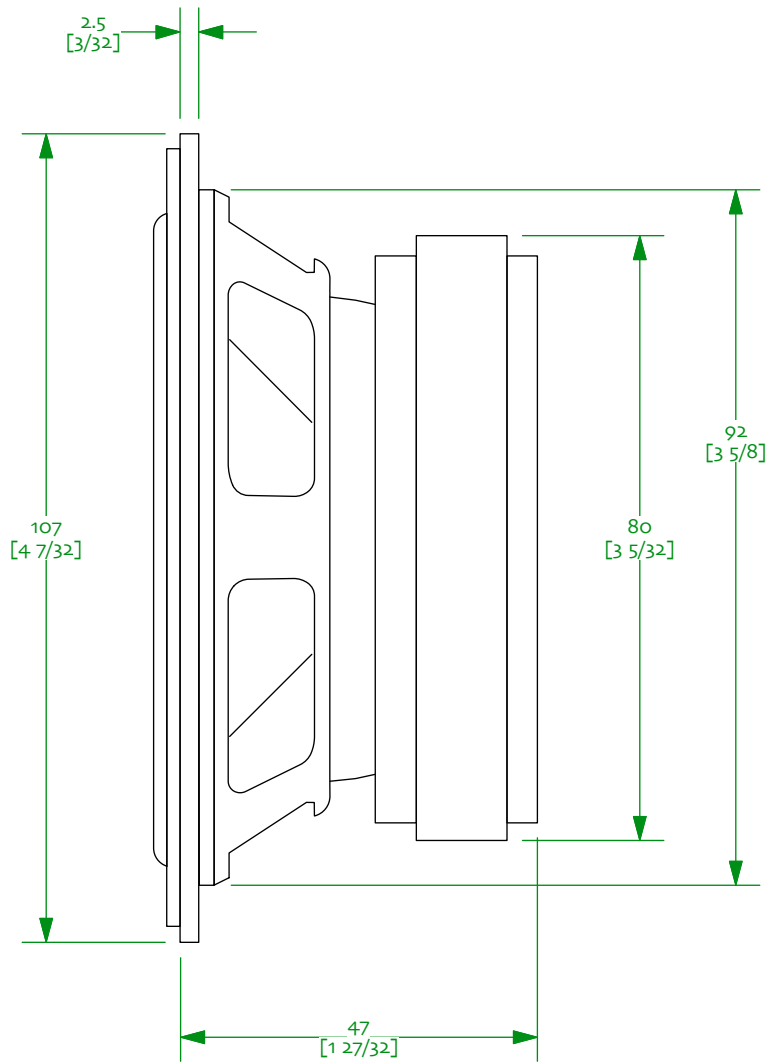

Fostex FE103 S01

Dimensions ov9

24-april-2018 | designed & drawn by D Dlugos
 © 2009-2016 planet_10 enterprises limited
 for licenced use only